

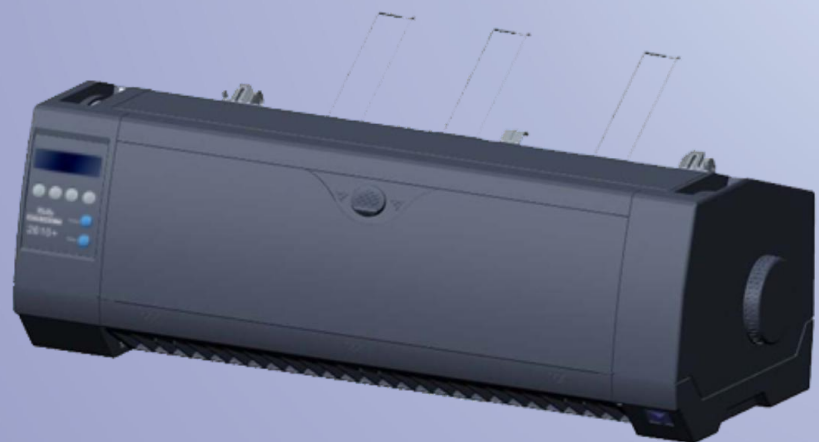

User Manual

2600+/2610+ Matrix Printer



Important Safety Instructions (English)

Read the following instructions thoroughly before starting up your printer.

- Never carry out maintenance or repair work yourself. Always contact a qualified service technician.
- Keep this Operator's Manual in a place which is easily accessible at all times.
- Place the printer on a solid and even base so that it cannot fall.
- Never place the printer in the vicinity of inflammable gas or explosive substances.
- Ensure the printer is connected to a socket with the correct mains voltage.
- Always disconnect the printer from the mains before opening the device to perform maintenance work or remedy errors.
- Do not expose the printer to high temperatures, direct sunlight or dust.
- Keep all liquids away from the printer.
- Protect the printer from shock, impact and vibration.
- Make sure that the printer and computer are switched off before connecting the data cable.
- The print head will become very hot during printing; avoid contact with the print head after printing has finished.
- Do not perform any operation or action in any way other than those provided in this manual. When in doubt, contact your dealer or your customer support.



The device and mains-socket must all times be easily accessible.

Wichtige Sicherheitshinweise (German)

Lesen Sie bitte diese Sicherheitshinweise durch, bevor sie den Drucker in Betrieb nehmen.

- Führen Sie Wartungsarbeiten und Reparaturen keinesfalls selbst aus, sondern verständigen Sie immer einen qualifizierten Servicetechniker.
- Bewahren Sie diese Dokumentation an einem jederzeit zugänglichen Ort auf.
- Den Drucker auf stabilem und ebenem Untergrund so aufstellen, dass er nicht zu Boden fallen kann.
- Stellen Sie den Drucker keinesfalls in der Nähe von leicht entzündlichen Gasen oder explosiven Stoffen auf.
- Den Drucker nur an eine Steckdose mit der richtigen Spannung anschließen.
- Wenn Sie den Drucker vom Netz trennen wollen, den Drucker ausschalten und immer den Netzstecker an der Steckdose ziehen.
- Den Drucker weder hohen Temperaturen noch direktem Sonnenlicht und Staub aussetzen.
- Keine Flüssigkeiten mit dem Drucker in Berührung bringen.
- Den Drucker keinen Erschütterungen, Stößen oder Vibrationen aussetzen.
- Sicherstellen, dass der Drucker und der Computer ausgeschaltet sind, bevor das Datenkabel angeschlossen wird.
- Der Druckkopf wird während des Druckens heiß. Vor dem Berühren deshalb einige Zeit abkühlen lassen.
- Weichen Sie bei der Bedienung des Druckers nicht von den Anweisungen in der Dokumentation ab. Bei Unklarheiten wenden Sie sich bitte an Ihren Händler oder Ihren Kundendienst.
- Maschinenlärminformationen – Verordnung – 3.GPSGV, der höchste Schalldruckpegel beträgt 70 dB(A) oder weniger gemäß EN ISO 7779.



Das Gerät und die Netzsteckdose müssen jeder Zeit leicht zugänglich sein.

Consignes importantes de sécurité (French)

Lire attentivement les instructions suivantes avant de mettre l'imprimante en service.

- Ne jamais effectuer soi-même les travaux d'entretien et de réparations. Contacter toujours un dépanneur qualifié.
- Placer l'imprimante sur un support stable de façon à ce qu'elle ne puisse pas tomber.
- Ne jamais placer l'imprimante à proximité de sources de gaz aisément inflammables ou de substances explosives.
- Ne connecter l'imprimante à une prise que lorsque la tension est correcte.
- Pour déconnecter l'imprimante de l'alimentation principale, mettre l'imprimante hors tension et toujours débrancher le connecteur secteur de la prise murale.
- Ne pas exposer l'imprimante à des températures élevées, à la lumière directe du soleil ou à la poussière.
- Ne pas mettre l'imprimante en contact avec des liquides.
- Ne pas exposer l'imprimante à des chocs, impacts ou vibrations.
- S'assurer que l'imprimante et l'ordinateur sont hors tension avant de connecter le câble de données.
- La tête d'impression est brûlante pendant l'impression. C'est pourquoi laissez-la refroidir quelques instants avant d'y toucher.
- N'exécutez aucune opération ni action d'une autre manière que celle indiquée dans ce manuel. En cas de doute, veuillez contacter votre distributeur ou service après-vente.



Le dispositif et la prise principale doivent toujours être accessibles facilement.

Indicazioni di sicurezza importanti (Italian)

Prima di mettere in funzione la stampante, leggere attentamente le seguenti indicazioni.

- Non eseguire mai da sé gli interventi di manutenzione e riparazione, ma rivolgersi sempre a un tecnico di assistenza qualificato.
- Conservare le presenti istruzioni per l'uso in un luogo sempre accessibile.
- Collocare la stampante su una superficie stabile, per evitare che cada a terra.
- Non collocare la stampante in prossimità di gas facilmente infiammabili o di sostanze esplosive.
- Collegare la stampante a una presa di corrente con tensione adeguata.
- Per scollegare la stampante dalla rete di alimentazione, spegnere la stampante e disinserire sempre il connettore di rete dalla presa.
- Non esporre la stampante ad elevate temperature né alla luce solare diretta e alla polvere.
- Evitare il contatto della stampante con liquidi.
- Non esporre la stampante a colpi, scosse o vibrazioni.
- Verificare che la stampante e il computer siano spenti prima di collegare il cavo di trasmissione dati.
- Durante la stampa, la testina si surriscalda notevolmente. Prima di toccarla, se necessario opportuno quindi lasciarla raffreddare qualche istante.
- Non eseguire alcuna operazione o azione se non nella maniera descritta nel presente manuale. In caso di dubbio, contattare il rivenditore o dalla società incaricata dell'assistenza.



Il dispositivo e la presa di corrente devono essere sempre facilmente accessibili.

Instrucciones de seguridad importantes (Spanish)

Lea las siguientes instrucciones con esmero antes de poner la impresora en servicio.

- Nunca lleve a cabo trabajos de mantenimiento o reparación Ud. mismo, sino consulte a un técnico de servicio calificado.
- Guarde las presentes instrucciones de servicio en un lugar de fácil acceso en cualquier momento.
- Ponga la impresora sobre un base estable de manera que no pueda caer al suelo.
- Nunca coloque la impresora en la vecindad de gases de fácil inflamabilidad o sustancias explosivas.
- Asegure conectar la impresora sólo a un enchufe con un voltaje correcto.
- Cuando quiera desconectar la impresora de la red, apague la impresora y siempre tire la clavija de alimentación del enchufe.
- No exponga la impresora a temperaturas altas, a la luz solar directa y al polvo.
- No ponga la impresora en contacto con fluidos.
- Nunca exponga la impresora a sacudidas, choques o vibraciones.
- Asegúrese de que la impresora y el ordenador estén apagados antes de conectar el cable de datos.
- La cabeza de impresión se pone muy caliente durante la impresión. Por lo tanto, deje enfriarlo algún tiempo antes de tocarla.
- No permita que se realice cualquier operación o acción de una forma diferente a lo que se señala en el manual. En caso de duda, póngase en contacto con su comerciante o con su servicio post-venta.



El dispositivo y la toma de corriente deben estar ubicados de forma que sea fácil acceder a ellos.

Правила по технике безопасности. (Russian)

Прочитайте, пожалуйста, инструкцию по технике безопасности перед включением в работу принтера.

- Не выполняйте технические работы и ремонт техники самостоятельно, но сообщайте о неисправностях квалифицированным сервисным техникам.
- Данная инструкция должна быть всегда доступна каждому пользователю.
- Установите принтер на ровном и стабильном месте так, чтобы он не смог упасть на пол.
- Ни в коем случае не ставьте принтер вблизи легко воспламеняющихся газов и взрывчатых веществ.
- Включайте принтер в розетку только с соответствующим напряжением.
- Если Вы хотите отключить принтер от напряжения, сначала выключите принтер сам и затем выньте штекер из розетки.
- Берегите принтер от нагревания, от попадания на него прямых солнечных лучей и пыли.
- Не допускайте попадания жидкости на принтер.
- Нельзя подвергать принтер тряске, ударам и вибрации.
- Убедитесь, что принтер и компьютер выключены, только после этого соедините принтер с компьютером.
- Печатающая головка нагревается во время работы принтера. Поэтому подождите какое-то время, прежде чем дотронуться до нее.
- Пользуйтесь принтером так, как это написано в документации. Если у Вас возникают неясности, обращайтесь с вопросами к Вашим продавцам или в сервисный центр.



Устройство и розетка должны быть всегда легко доступна.

Instruções Importantes sobre Segurança (Portuguese)

Leia as instruções de segurança antes de usar a impressora.

- Consulte sempre um técnico qualificado para executar uma reparação .
- Coloque a impressora sobre uma base sólida e nivelada, para que ela não sofra quedas.
- Jamais instale a impressora nas proximidades de lugares onde haja gás inflamável ou substâncias explosivas.
- Assegure-se de conectar a impressora à tomada elétrica com a voltagem apropriada.
- Quando desligar a impressora da rede, desligue sempre a impressora e retire o cabo da tomada.
- Não exponha a impressora a temperaturas altas ou luz solar direta.
- Não aproxime substâncias líquidas da impressora.
- Proteja a impressora de choques, impactos e vibrações.
- Desligue a impressora e o computador antes de conectar o cabo da rede.
- A cabeça da impressora pode ficar muito quente . Portanto, espere algum tempo antes de tocá-la.
- Não faça nenhuma operação ou ação além das recomendadas neste manual. Em caso de dúvida, contate seu revendedor ou companhia de serviço.



A impressora e a tomada devem ser facilmente em todos os momentos acessíveis.

Önemli Güvenlik Talimatları (Turkish)

Lütfen, yazıcıyı işleme geçirmeden önce bu güvenlik talimatlarını bütünüyle dikkatle okuyun.

- Bakım ve tamir çalışmalarını kesinlikle ve hiçbir surette kendi başınıza yapmayın; her zaman kalifiye bir uzman servis-teknişyenine haber verin.
- Yazıcıyı, üzerinden yere düşmesim mümkün olmayacak sabit ve düz bir zemine yerleştirin.
- Yazıcıyı kesinlikle ve hiçbir surette kolayca yanabilecek gaz veya patlayıcı maddeler içeren nesnelere yakınına koymayın.
- Yazıcı bakım kablosunu sadece doğru gerilime sahip bir prize takın.
- Yazıcıyı şebeke ağından ayırmak istediğinizde, yazıcıyı kapatın ve ağ-fişini her zaman prizden çıkartın.
- Yazıcıyı ne yüksek ısı ne de doğrudan güneş ışığına ve toza mâruz kalan mekânlarda bulundurun.
- Yazıcı hiçbir sıvı maddeyle temasta olmamalıdır.
- Yazıcı hiçbir sarsıntıya, darbeye veya titreşime mâruz kalmamalıdır.
- Veri kablosu bağlanmadan önce hem yazıcının hem de bilgisayarın kapalı olduklarından emin olmalısınız.
- Yazıcının başı basma esnasında yüksek ısıya ulaşır. Bu yüzden lütfen dokunmadan önce kısa süre soğumasını bekleyin.
- Yazıcının işletimi ve kullanımında bu dokümantasyondaki talimatların hiç dışına çıkmayın. Sorunlu görünen hususlarda lütfen imâlatçınıza veya müşteri hizmetleri servisimize başvurun.



Cihaz ve elektrik prizinin her zaman kolayca erişilebilir olması gerekir.

TRADEMARK ACKNOWLEDGEMENTS

“IBM” is a trademark of International Business Machines Corporation.

“EPSON” is a trademark of Epson America Incorporated.

“DEC” is a trademark of Digital Equipment Corporation.

“Centronics” is a trademark of Centronics Data Computer Corporation.

“DOS” is a trademark of Microsoft Corporation.

“SAP” is a trademark of SAP AG.

“Windows”, “Windows 7”, “Windows 8”, “Windows 10”, “Windows 95”, “Windows 98”, “Windows NT”,

“Windows 2000”, “Windows 2003/2008/2013 Server”, “Windows XP” and “Windows Vista” are trademarks of Microsoft Corporation.

All other product names and company names appearing in this manual are the registered trademarks or trademarks of the individual companies.



This device fulfils the European standards requirements by complying with the Directive relating to electromagnetic compatibility and relating to low-voltage electrical equipment. Furthermore, it fulfils the requirements for RoHS and RED if applicable.

Conformity with the above-mentioned Directives is indicated by the CE symbol attached to the device.

Note: Conformity may be affected by:

- using interface cables not complying with the specifications
- non-observance of important instructions in the operator’s manual
- installing components not approved for this device by the manufacturer
- unauthorized manipulation



Dieses Gerät erfüllt die Anforderungen der Europäischen Normen durch Einhaltung der Richtlinien bezüglich der Elektromagnetischen Verträglichkeit sowie bezüglich Elektrischer Betriebsmittel mit Niederspannung. Des Weiteren werden die Anforderungen bezüglich RoHS und falls anwendbar RED erfüllt.

Die Konformität zu den oben angeführten Richtlinien ist durch das am Gerät angebrachte CE-Zeichen gekennzeichnet.

Hinweis: Die Konformität kann beeinflusst werden durch:

- Benutzung von nicht spezifizierten Schnittstellen
- Nichtbeachtung wichtiger Hinweise der Bedienungsanleitung
- Ersetzen von Bauteilen, die nicht vom Hersteller für dieses Gerät freigegeben wurden
- Eingriffe durch Unbefugte



This device complies with the requirements of the United Kingdom (UK) legislation of Electrical Safety Regulations, Electromagnetic Compatibility Regulations, if applicable the Radio Regulations and the Restriction of the Hazardous Substances in Electrical and Electronic Equipment Regulations.

TABLE OF CONTENTS





1 Printer at a glance.....	1
1.1 Unpacking the printer.....	1
1.2 Remove transport locks.....	1
1.3 Prepare your printer.....	2
1.4 Parts description.....	4
2 Installation.....	5
2.1 Placing the printer.....	5
2.2 Connecting the printer.....	6
2.2.1 Parallel interface (IEEE 1284).....	6
2.2.2 USB 2.0 (Full Speed).....	6
2.2.3 Ethernet.....	6
2.2.4 Serial Interface (RS-232C) as option.....	7
2.2.5 Connecting the power.....	7
2.2.6 Switch on the printer.....	7
2.3 Installing the ribbon cartridge.....	8
3 Installing the paper.....	10
3.1 Adjusting the print gap for various form thicknesses.....	10
3.2 Paper path introduction.....	11
3.2.1 Cut sheet paper handling (front friction only).....	11
3.2.2 Fanfold paper handling.....	12
3.2.3 Top-Of-Form adjustment.....	16
4 Control Panel Operation.....	17
4.1 Operation of the LCD Panel.....	17
4.2 The LC display.....	17
4.3 Online mode.....	18
4.4 Offline mode.....	18
4.5 Setup mode.....	19
4.6 Power on functions.....	19
5 Printer Setting.....	20
5.1 Setting the parameters through the LCD Panel.....	20
5.1.1 Enabling access to menu mode.....	20
5.1.2 Menu configurations.....	21
5.1.3 Menu handling.....	23
5.1.4 Selecting the LC display language.....	24
5.2 Menu structure.....	25
5.3 Full list parameters setting.....	26
5.3.1 Menu Configuration list.....	26
5.3.2 Advanced Menu.....	34
5.4 Display messages.....	37
5.5 USB host interface.....	38
5.5.1 Firmware Download.....	38
5.5.2 Configuration File Upload.....	38
5.5.3 Configuration File Download.....	38
6 Web Panel and Internal Ethernet Interface.....	39
6.1 Summary.....	39
6.1.1 Introduction.....	39
6.1.2 Supported Environments.....	39
6.1.3 Network Interface and Cabling.....	39
6.1.4 Connecting the Printer.....	39
6.1.5 Network Interface Status.....	39
6.1.6 IPv6 Functionality.....	40
6.2 IP Configuration.....	40
6.2.1 Network IP Configuration.....	40
6.2.2 Assigning the IP Address.....	40

6.3 WebPanel.....	42
6.3.1 Introduction.....	42
6.3.2 Web Browser.....	42
6.3.3 Access to WebPanel.....	43
6.3.4 Access to Config Tool.....	44
6.3.5 Printer Status.....	44
6.3.6 Printer Configuration.....	45
6.3.7 Printer Actions.....	48
6.3.8 Load Configuration.....	48
6.3.9 Save Configuration.....	49
6.3.10 Retrieve Configuration From Printer.....	49
6.3.11 Send Configuration to Printer.....	50
6.3.12 Report.....	52
6.3.13 Reset Printer.....	52
6.3.14 Panel Lock On/Off.....	52
6.3.15 Download Firmware.....	52
6.3.16 TallyCom Status.....	55
6.3.17 Advanced Configuration.....	55
6.3.18 General.....	56
6.3.19 TCP/IP.....	57
6.3.20 SNMP.....	58
6.3.21 Password.....	59
6.3.22 User Name.....	59
6.3.23 Resetting Password.....	59
6.3.24 Logical Printers.....	60
6.3.25 String Replacement Example Plain Text.....	61
6.3.26 Logout of TallyCom.....	62
6.3.27 Restart TallyCom.....	62
6.3.28 Virtual Control Panel.....	63
7 Addendum.....	64
7.1 Character Set.....	64
7.2 Control Codes Summary.....	69
7.2.1 PJI commands.....	78
7.2.2 Barcode.....	78
7.2.3 List of available MTPL barcodes.....	79
7.2.4 US Postnet barcode.....	80
7.2.5 Royal Mail Customer barcode.....	81
7.2.6 KIX barcode.....	81
7.2.7 USPS Intelligent Mail barcode.....	82
7.2.8 LC printing.....	82
7.2.9 List of additional control Codes.....	83
7.3 Interfaces Specifications.....	84
7.3.1 Parallel I/O IEEE 1284.....	85
7.3.2 Ethernet I/O 10/100 Multitprotocol.....	86
7.3.3 USB 2.0 I/O – Full Speed.....	87
7.3.4 Optional Serial Interface RS232C.....	88
8 Options and accessories.....	94
8.1 Options.....	94
8.2 Consumables.....	94
8.3 Accessories.....	95
9 General Specifications.....	96
9.1 Printer Specifications.....	96
9.2 Non-Scalable Fonts, Code Pages and National Character Sets.....	99
9.3 Paper Specifications.....	101
9.3.1 Standard Tractor (Front, Rear and Pull position) – narrow and wide versions.....	101
9.3.2 Front Feed / Manual Insertion – Narrow and wide versions.....	102
9.3.3 Paper Weights.....	102
10 Maintenance.....	103

10.1 Cleaning.....	103
10.1.1 Cleaning and Vacuuming the Printer.....	103
10.1.2 Cleaning the Paper Rollers.....	103
10.2 Troubleshooting.....	104
10.2.1 Print Quality Problems and Solutions.....	104
10.2.2 Paper Handling Problems and Solutions.....	105
10.2.3 Operating Problems and Solutions.....	105
FCC STATEMENT.....	106

Symbol Description

The symbols in this manual are identified by their level of importance, as defined below. Read the following carefully before handling the product.

	CAUTION: Provides information that must be observed to prevent damage to the equipment or data loss .
	NOTE: Advises you of information that is essential to complete a task.
	CAUTION: Keep your body away from moving part.
	CAUTION: Hot ! Do not touch the parts till the printer has been switch off in half hour, otherwise it will hurt your fingers.
	CAUTION: Sharp edges, do not touch.

1 Printer at a glance

1.1 Unpacking the printer

Besides this manual, the package will contain: a power cord, a ribbon cartridge, a tractor, 6 pieces of U-wire paper support.

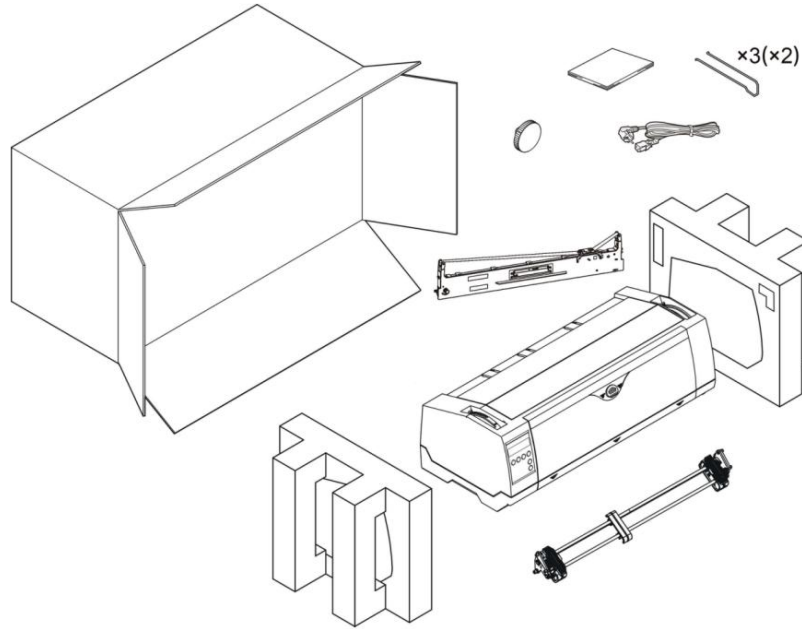

1.2 Remove transport locks

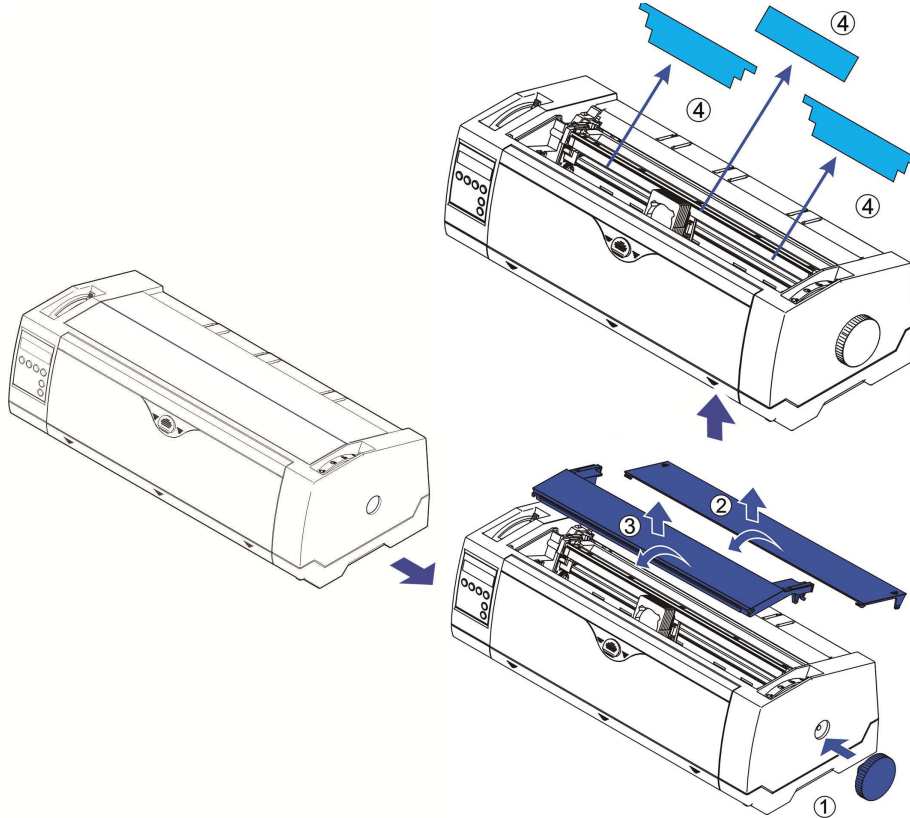

1.3 Prepare your printer

- Front View

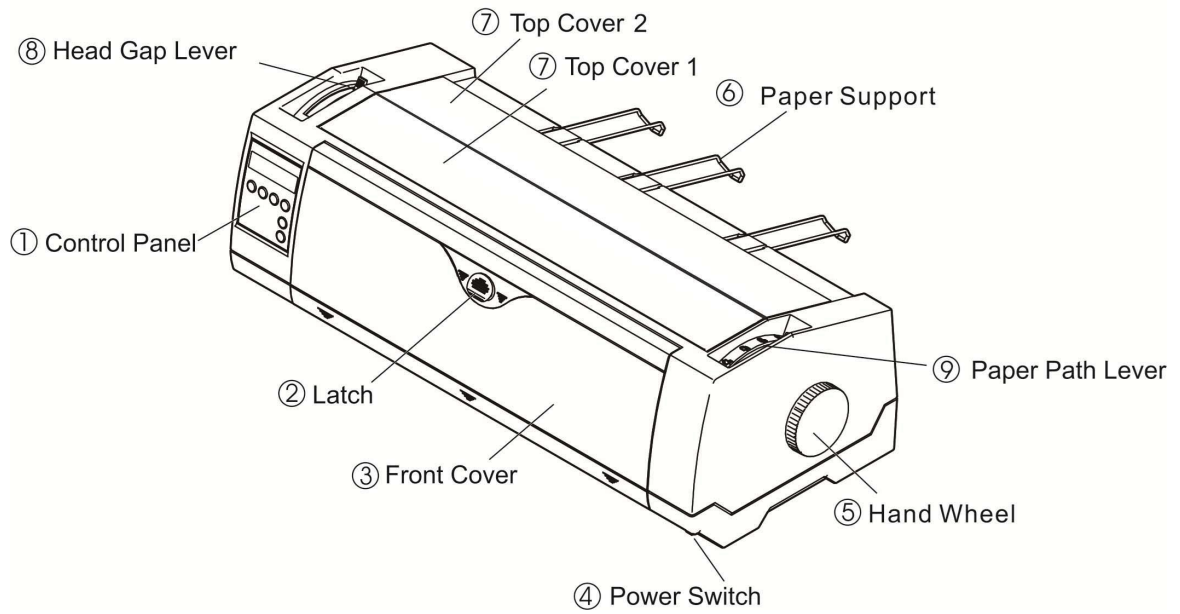

- Rear View

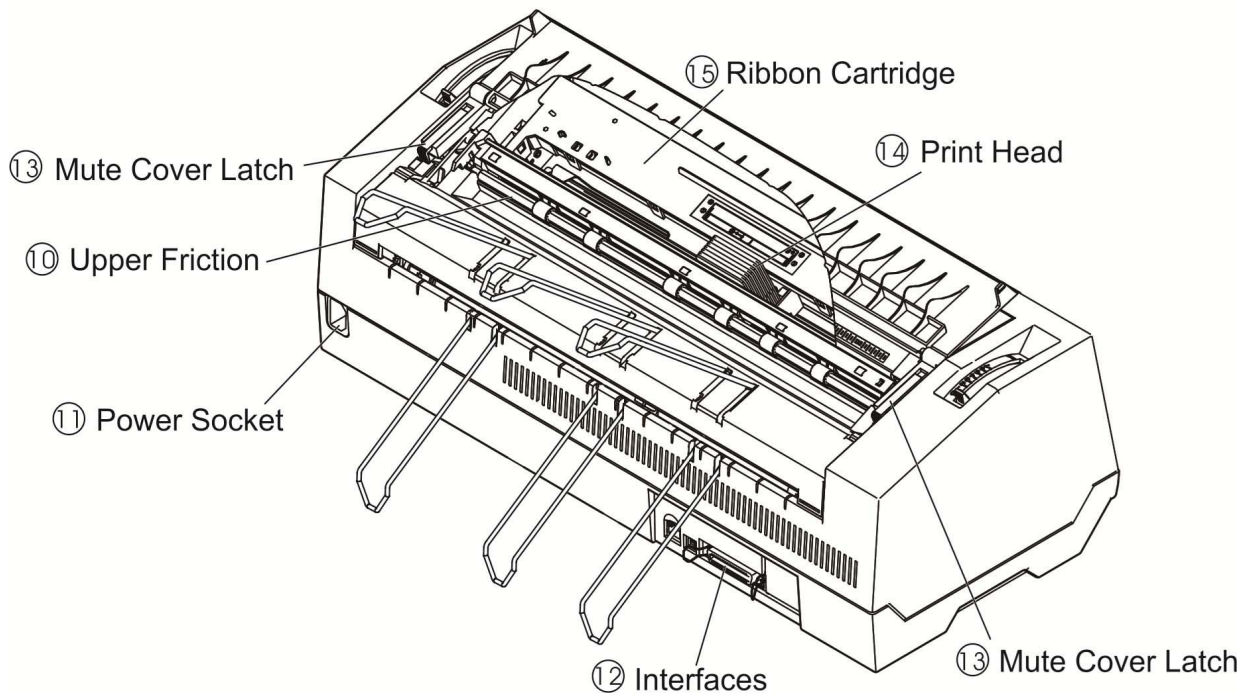

- For Fanfold

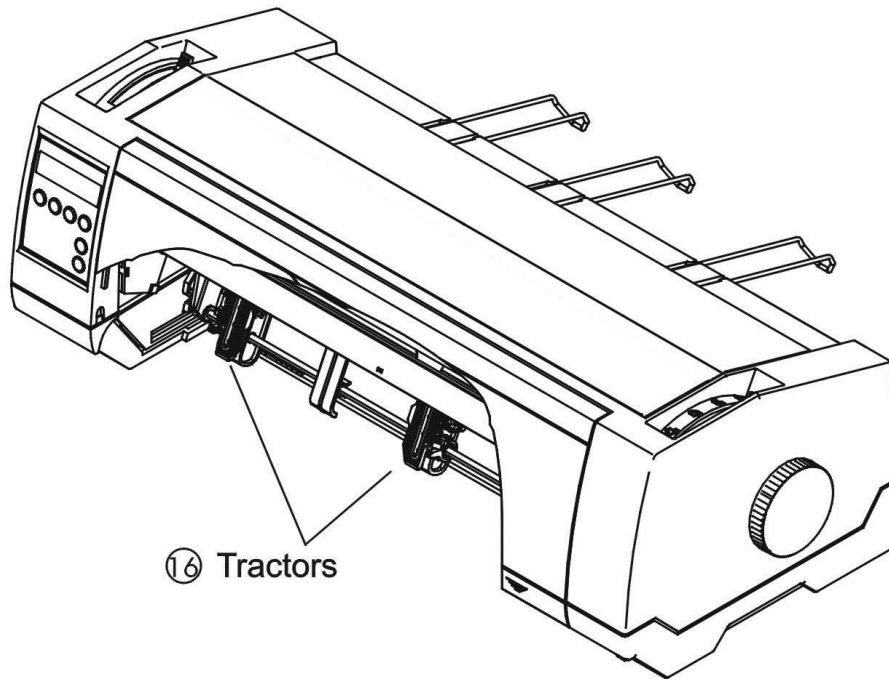

- For Cut Sheets

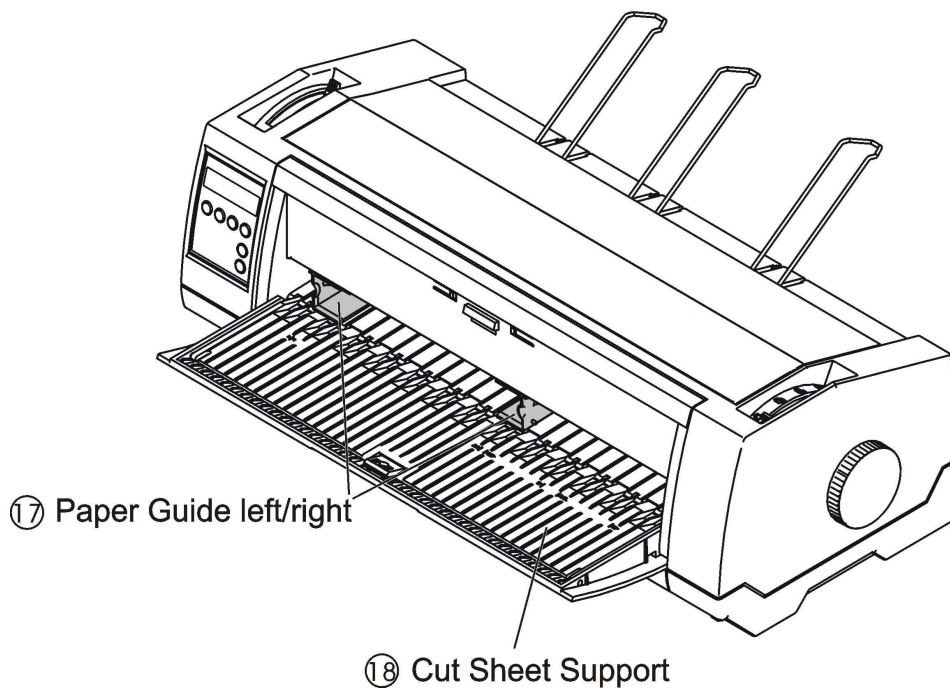

1.4 Parts description

1	Control Panel	A LCD display and two keys indicates the operating status and allows simple settings of the printer.
2	Latch	Sliding it down unfolds the cut sheet support.
3	Front Cover	Unlocking the front cover unfolds the cut sheets support.
4	Power Switch	Turns on and off the printer.
5	Hand Wheel	Turn the knob to load or clear the paper. It should be inserted the full way until you can hears some sort of "Click".
6	Paper Support	At slanted position, it stacks cut sheets; at flat position, it separates fanfold printouts from incoming forms.
7	Top Covers 1&2	Protect the internal parts and reduce the noise.
8	Head Gap Lever	Adjusts the gap between the print head and various form thickness.
9	Paper Path Lever	Selects various paper sources.
10	Upper Friction	Guides the form when cut sheets or fanfold forms are used.
11	Power Socket	A power cord is plugged into the socket to supply the power.
12	Interfaces	The interface cable of the host computer is plugged into one of the interfaces.
13	Mute Cover Latch	You must open it before you open the top cover 1.
14	Print Head	Utilizes 24 needles to strike on ink ribbon and paper.
15	Ribbon Cartridge	Holds the ink ribbon fabric.
16	Tractors	Holds and transports fanfold forms.
17	Paper Guides Left/Right	Sliding the guides varies the form width and the left margin on a cut sheet.
18	Cut Sheet Support	A flat surface supports a sheet or multi-part form.

2 Installation

2.1 Placing the printer

Place the printer on a solid, flat, stable surface such that the printer sits firmly and cannot move. Select an environment with sufficient ventilation, easy access to the control panel and paper input areas as well as the printed output.

When selecting the printer location, observe the following additional requirements:

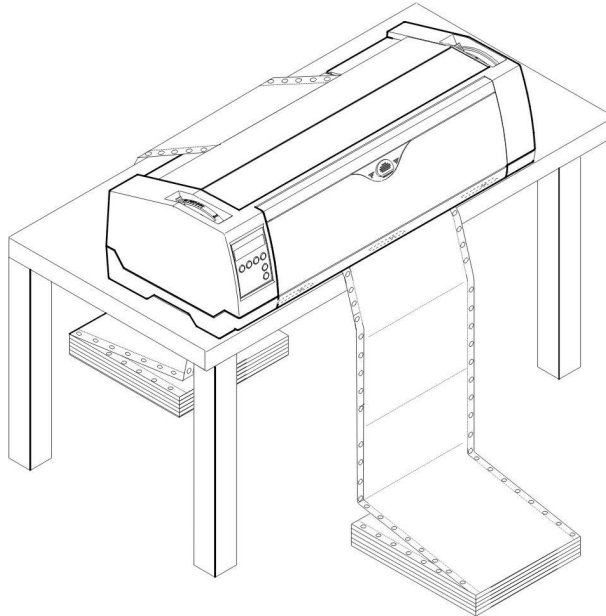

- 1) Never place the printer near to any flammable gas or explosive substances.**
- 2) Do not expose the printer to direct sunlight. If you cannot avoid placing the printer near a window, protect it from the sunlight with a curtain.**
- 3) When connecting a computer to the printer, make sure the maximum recommended cable length is not exceeded.**
- 4) Ensure sufficient distance between the printer and any heating devices/radiators.**
- 5) Avoid exposing the printer to extreme temperature or air humidity fluctuations. Above all, avoid dusty environments.**

2.2 Connecting the printer

This printer is configured with a Parallel, USB and Ethernet interface as standard. An optional Serial interface can be installed additionally.

2.2.1 Parallel interface (IEEE 1284)

Make sure that the printer and the computer are switched off and connect the parallel cable between the printer and the computer. Lock the connector with the 2 clips on the printer interface connector; tighten up the 2 screws on the other end connecting to the computer.

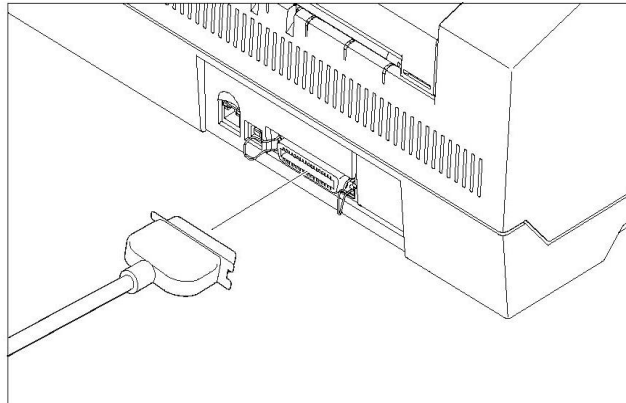

2.2.2 USB 2.0 (Full Speed)

Plug in the USB cable to the printer and the computer.

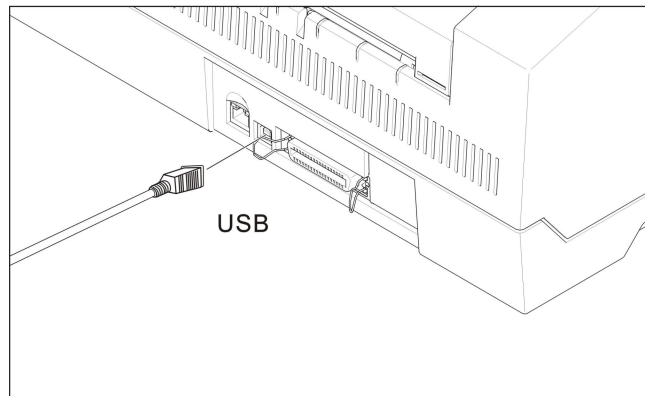

2.2.3 Ethernet

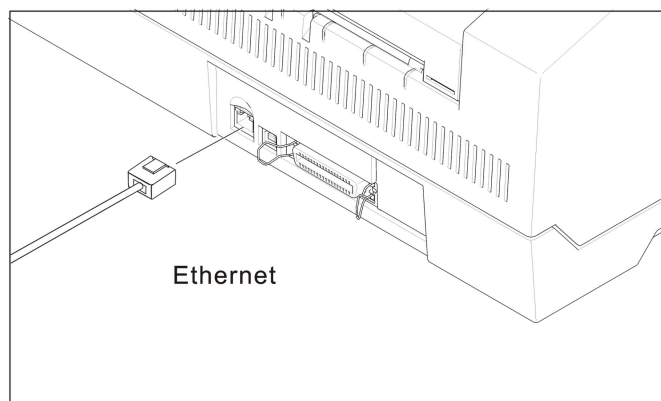

2.2.4 Serial Interface (RS-232C) as option

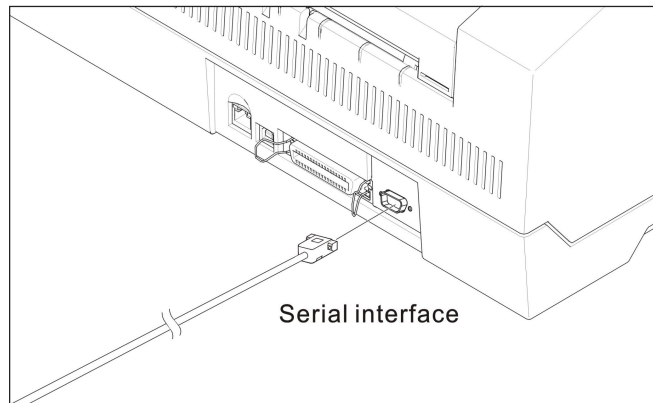

2.2.5 Connecting the power

Plug in the power cord to the printer power socket as shown in the diagram.

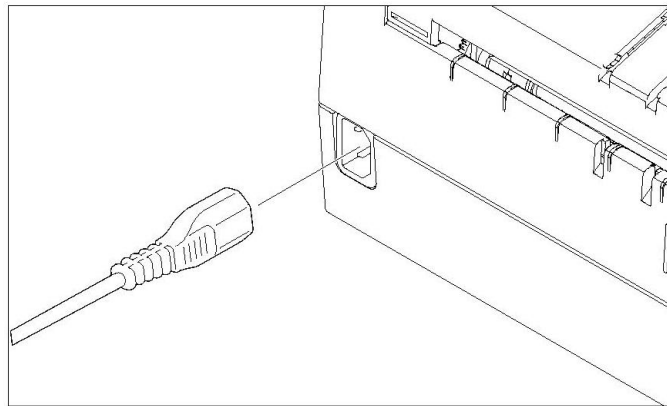

i **Connect the printer to the correct voltage power source.**
The socket-outlet shall be installed near the equipment and shall be easily accessible.

2.2.6 Switch on the printer

Switch on the printer as shown in the diagram.

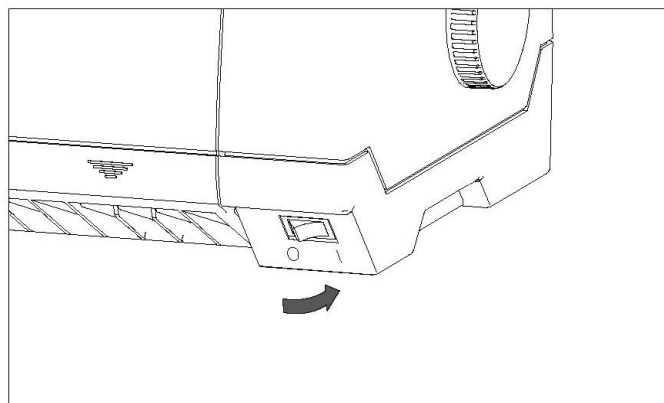

2.3 Installing the ribbon cartridge

- 1) Switch off the power.
- 2) Unfold the top cover and follow the steps 1.2.3.4.5 in the below picture.

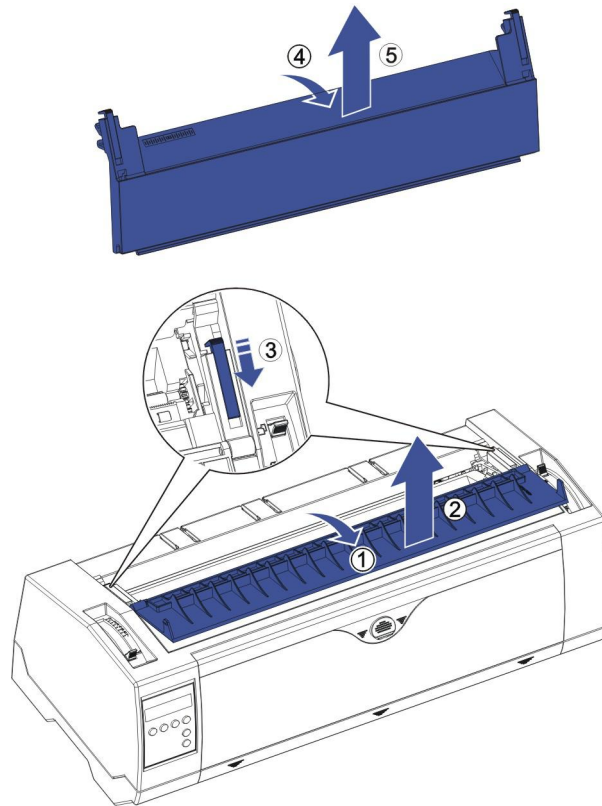

- 3) Flip the upper friction assembly

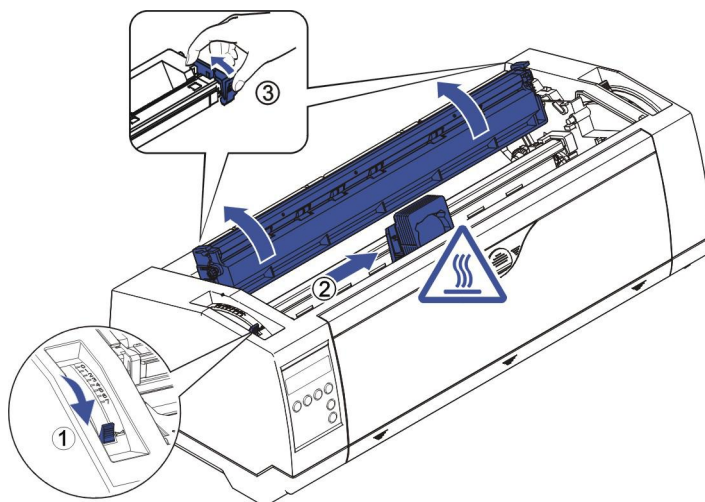

4) Insert the ribbon cartridge till it is tightly locked in position.

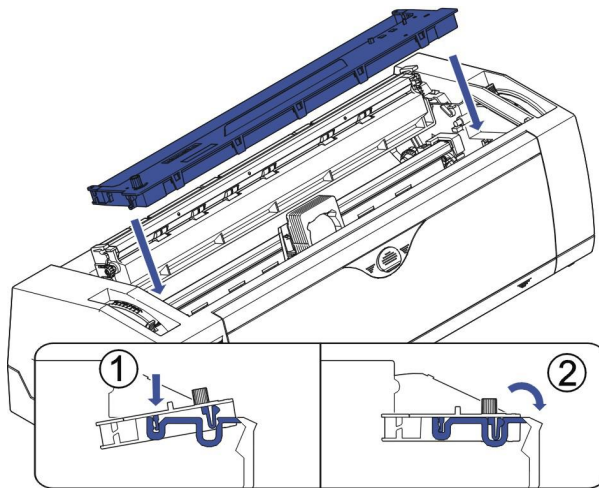

5) Take off the Ribbon Guide from Ribbon Cartridge and insert it between Carriage and Ribbon Mask.

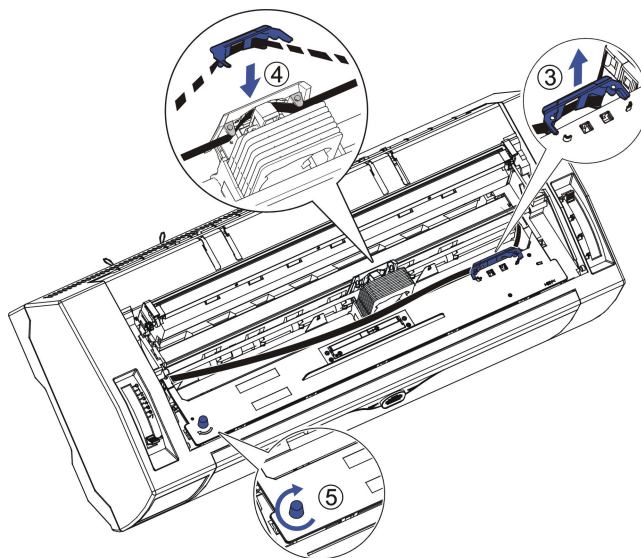

6) Turn the knob on the left hand side several times in order to tighten the fabric, and the fabric will slide downwards into the correct position between print head and ribbon mask after the moving.

7) Restore the upper friction assembly to its original position.



Print head may be hot, please move the printhead by moving the carriage.

3 Installing the paper

The printer can handle either single sheets or continuous forms. The printer is able to print up to 5 copies (original plus 5).

 To ensure the print quality and protect the print head, set a proper print gap by the gap lever (see 3.1) for the form thickness and do not load folded, damaged, wrinkled, or curled paper.

3.1 Adjusting the print gap for various form thicknesses

The print gap lever is on the left side of the printer inside the top cover.

Take care to adjust the print gap lever to a suitable position whenever you change the number of copies being printed. Using the wrong print gap may cause print head damage or paper jams.

The recommended gap lever position for different form thickness is:

Paper type	Lever position
1-part	1
Original + 1 copy	2
Original + 2 copies	3
Original + 3 copies	4
Original + 4 copies	5
Original + 5 copies	6

The position “Ribbon” only is suitable for loading the ribbon. When the lever is set higher than appropriate it will result in poor print. The ribbon and head life will be shortened.

3.2 Paper path introduction

3.2.1 Cut sheet paper handling (front friction only)

- 1) Place the paper path lever to the cut sheet position.
- 2) Unlock the front cover with the latch to unfold the cut sheet support.
- 3) Adjust the gap lever if necessary; see [3.1](#).

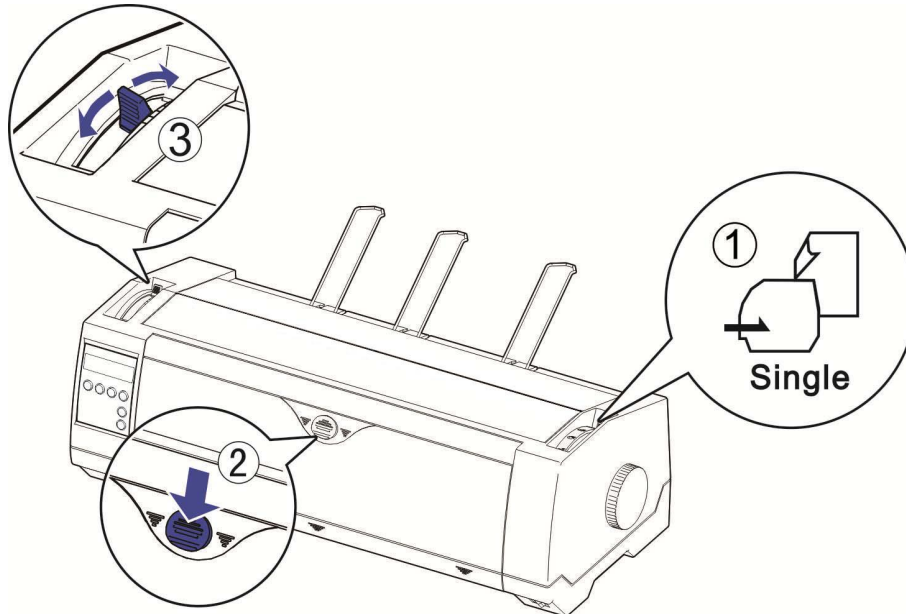

- 4) It is recommended to align the left paper guide exactly to the mark > | <. This marks the left edge of the stationery. Slide the right guide to the position of the right edge of the stationery.
- 5) Insert the stationery straightly all the way into the guided slot until it stops.

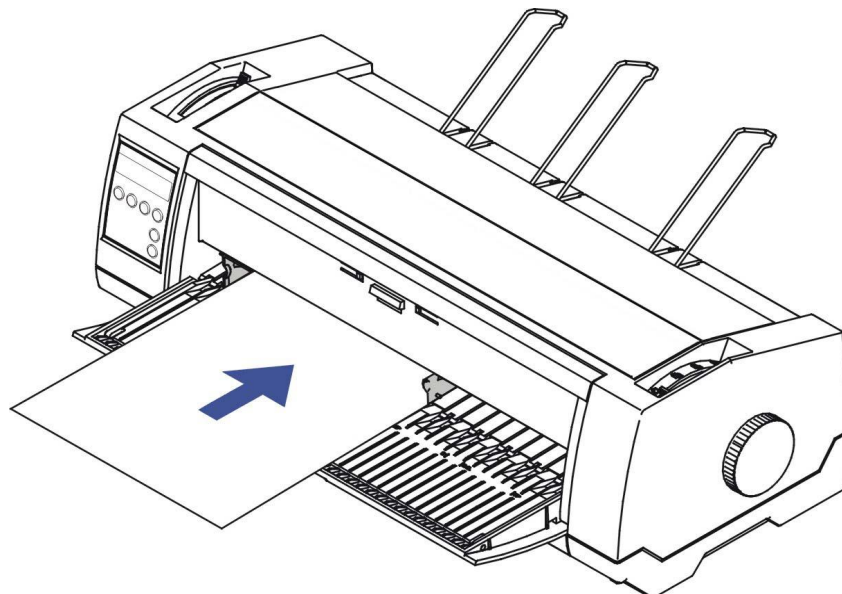

- 6) Press the load key to feed the paper to the correct print position, automatically. The printer clears the Paper End condition and goes into the ready or online state.

3.2.2 Fanfold paper handling

3.2.2.1 Front push tractors for fanfold

- 1) Close the front cover if previously opened. Switch the paper path lever to one of the desired tractor positions.
- 2) Move the paper path lever to the desired position.
- 3) Adjust the head gap lever if necessary.
- 4) Open the front cover by tilting the cover from bottom to the top, and make sure it's locked in place (see below pictures).

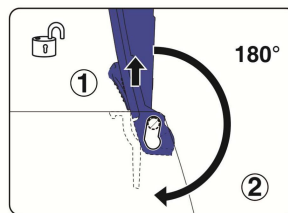
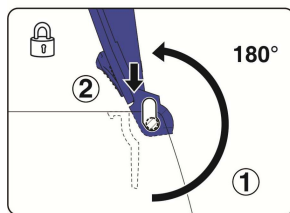
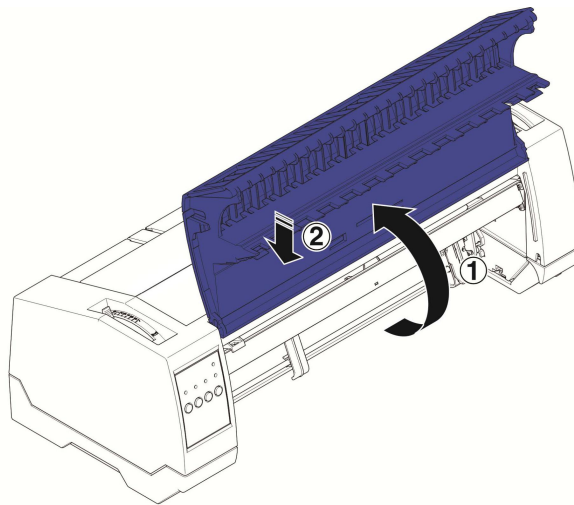
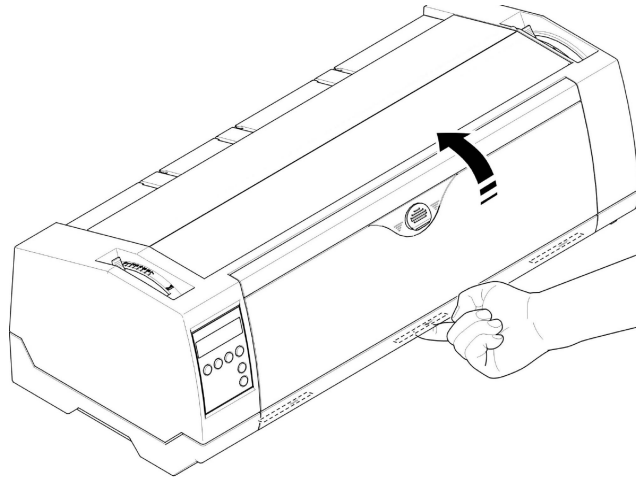

Lock the front cover in the way that is shown in the pictures. Make sure the front cover is locked.

- 5) If you do not need to adjust the left margin go to the next step. Open the right and left tractor flaps, insert fanfold paper into the left-hand tractor, and make sure that at least three paper transport holes are positioned on the tractor pins, close the tractor flap, open the latch lever and align the tractor so that the first printing position on the paper matches the IIIIXIIII mark on the printer housing, then lock the lever again.

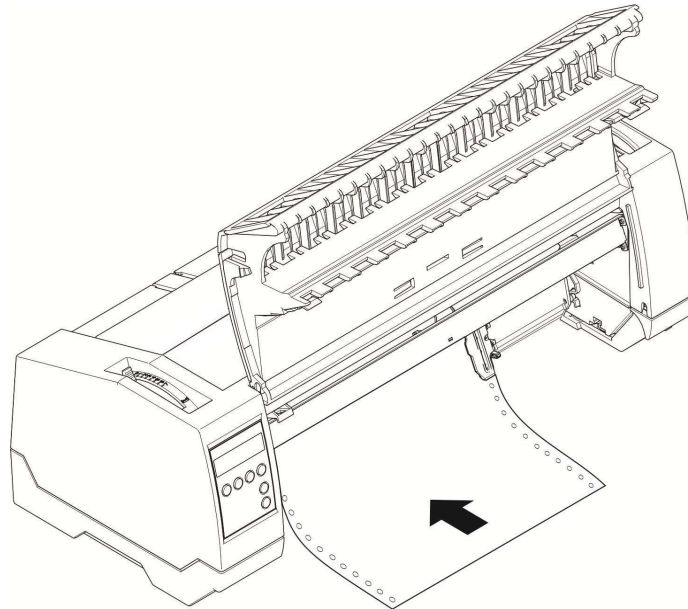

- 6) Align the right-hand tractor to the width of the paper and insert the paper (Make sure that it is inserted by the same length as on the left-hand tractor in order to avoid any paper jam). Then close the tractor flap and slide the tractor to the right until the paper is slightly tensioned, then lock the tractor.
- 7) Lower the front cover, switch the printer on. The active paper source (**TrFront**) appears in the display, the paper will automatically load when the printer is in online mode and receives data from the computer. Also, you can press the load key (**key 4**) only to load paper before starting the printout.

3.2.2.2 Rear tractors for fanfold 

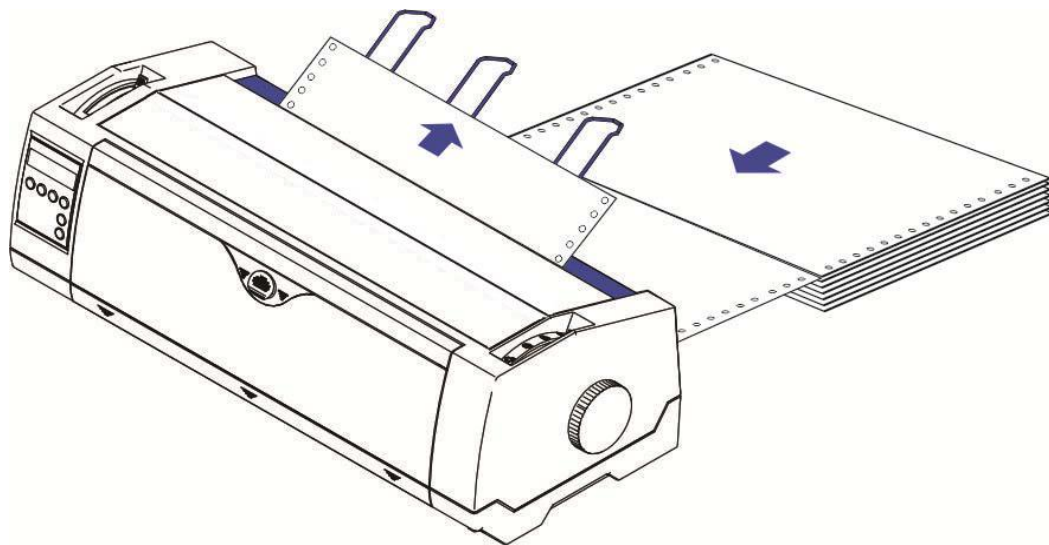
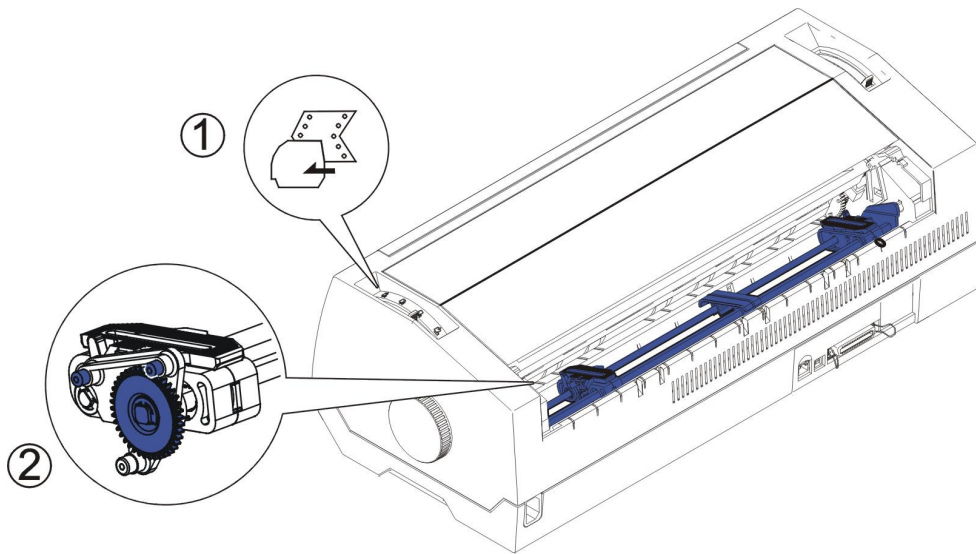

3.2.2.3 Top pull tractors for fanfold 

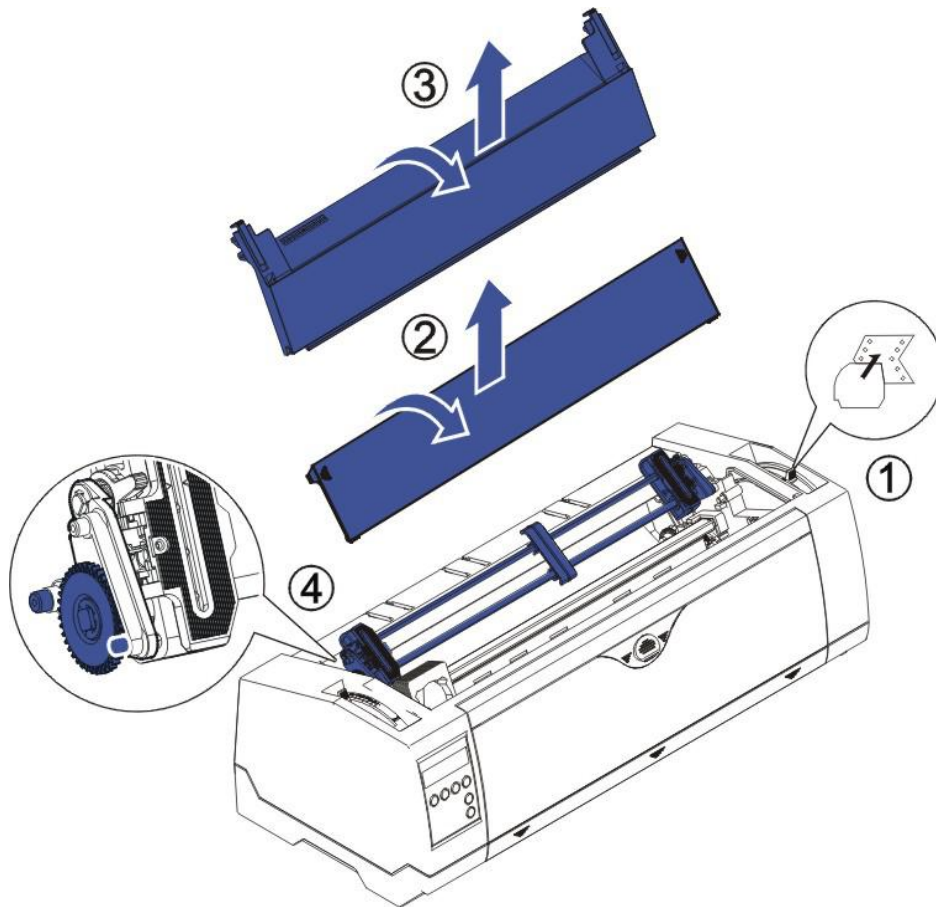

i For the steps ② and ③, please refer to the [2.3](#)

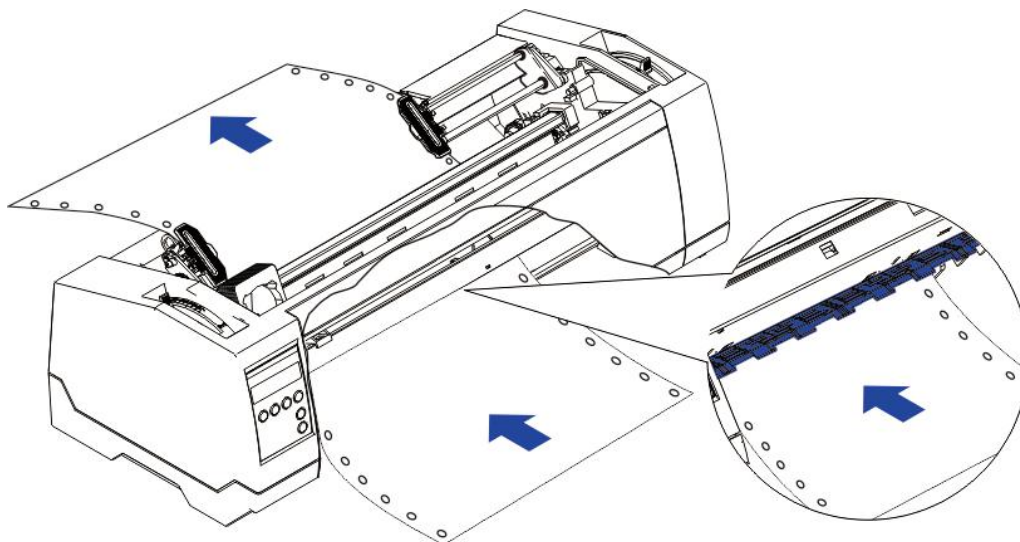

3.2.3 Top-Of-Form adjustment

For pull tractor (PullTr), follow the steps below to adjust the first print position:

- 1) Remove Paper from printer.
- 2) Power on the printer.
- 3) Lift the Top Cover so you can see the transparent ribbon guide in front of the print head.
- 4) Install the paper into the pull tractor.
- 5) Move the paper with the hand wheel so the perforation of the fanfold paper lies exactly at the top of the transparent ribbon guide.

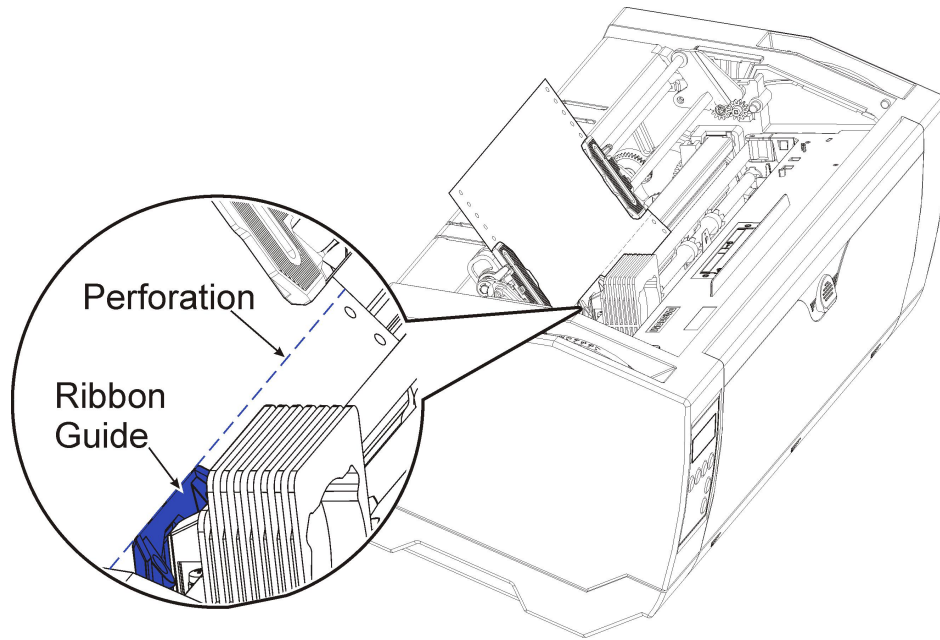

- 6) Close the Top Cover.
- 7) Press the Load key on the panel.
- 8) The printer now moves the paper to the correct first print position on a page (TOF).

4 Control Panel Operation

General functions for the keys are clearly designated on the Panel label. Some other special settings need pressing multiple switches simultaneously or holding some keys when powering on the printer. This Chapter will describe the functions of the keys and display on the Panel.

4.1 Operation of the LCD Panel

- The **Online** mode is the printer's normal operating mode. Data from your computer can be received and printed.
- In the **Offline** mode the link between printer and computer is interrupted, i.e. no data can be received and printed.
- In the **Setup** mode you can either select the printer menu or carry out the quick-switch function. The quick-switch option was included so that you can change the most important parameters (for example adjustments, character density, font, paper path, adjustments directly without having to enter them via the menu. The settings for the parameters character density and font are lost when the printer is switched off. They can be selected permanently in the menu mode of the printer.
- In the **Menu** mode further printer settings (line spacing, size of the interface buffer etc.) can be altered and saved permanently.

4.2 The LC display

The LC display tells you all the important printer settings and informs you which functions are currently assigned to which keys.

The upper line informs you that the printer is either in online or offline mode (in the example below the printer is in the Online mode), and the selected paper path (below: **TrFront** = tractor front mode).

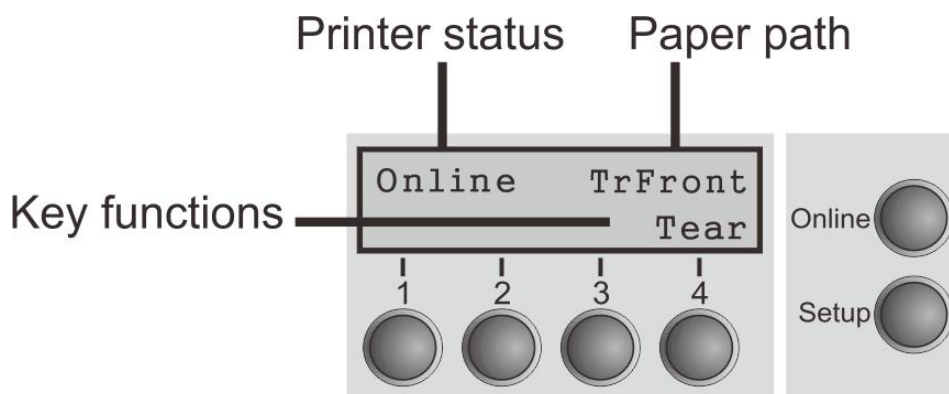

4.3 Online mode

After switching on, the printer is automatically set to online mode. Only in this mode can it receive data from the computer.

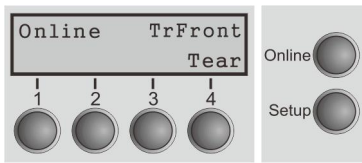

- **Online** key: Toggle between Online and Offline mode.
- **Tear** key (4): Activates the tear function when fanfold paper is loaded.

If **Load** is displayed above this key, no paper is loaded in the printer or the paper is in park position. In this case the display switches between **Online** and **Park Position**. Press the key to feed paper to the printing position.

- **Setup** key: Sets the printer to setup mode.

4.4 Offline mode

Only in this mode is it possible to perform step, line, or form feeds from the control panel, however, data cannot be received.

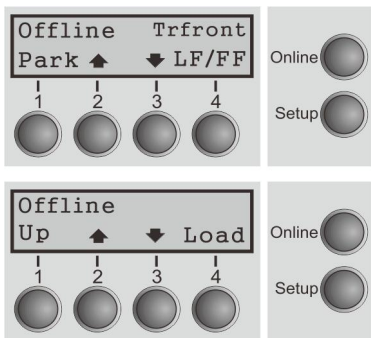

- **Park** key (1)
If fanfold paper is loaded in the printer, it is fed to the park position or the tear position. If a single sheet is loaded, it is ejected.
- **↑** key (2)
Each press: Paper is transported upwards step by step.
Holding: Continuous transport upwards.
- **↓** key (3)
Each press: Paper is transported downwards step by step.
Holding: Continuous transport downwards.
- **LF/FF** key (4)
Paper in the printer:
Each press: performs a line feed (LF).
Holding: performs a form feed (FF).
- **Load** key (4)
No paper in the printer: The press on this key loads the paper to the first print position.
- **Setup** key: Sets the printer to setup mode.
- **Online** key: Sets the printer to online mode.

4.5 Setup mode

In this mode, the following settings are available:

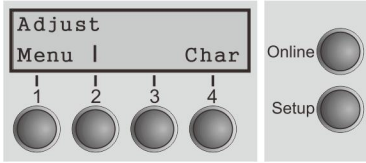

- **Setup** key: Sets the printer to setup mode, in which the following settings can be selected.
- **Menu** key (1): Other menu settings. Access may be disabled by menu settings (see note below).
- **Adjust** key (2): Sets the Tear position and first printing line (TOF). If you have the PullTr (Pull - Tractor) selected Adjust is not available.
- **Char** key (4): Sets the font and the number of characters per inch temporarily.



Access to the other menu settings (Menu) may be disabled by the manufacturer.

Proceed as follows to release this lock temporarily.

- 1) Switch off the printer for approx. 5 seconds.
- 2) Switch the printer on again keeping the Setup key pressed.

4.6 Power on functions

If you keep one of the following keys pressed during power-on until the printer has completed initialization, the corresponding function is activated:

- If you keep the **Online** key pressed while turning on the printer, you enter the printer's advanced menu mode. The advanced menu mode is described in the section [5.3.2](#) of this manual.
- If you keep the **Setup** key pressed while turning on the printer, you regain access to the printer menu if you had locked it before with the help of the Menu Lock function.
- If all four **function** keys (keys 1 to 4) are pressed simultaneously while turning on the power, all printer settings are reset to the default values, except the **Forml** (Form length) setting in advanced menu mode.
- Holding Function key 4 while turning on the printer prints out the parameter settings.

5 Printer Setting

(Programming via the control panel)

Apart from being able to control your printer via the applications software you use, you can also program the printer directly. There are two programming options you can use:

- Programming via the control panel.
- Programming via the interface using Escape sequences or control codes.



Settings made by escape sequences have priority over settings made in menu mode; therefore they will override these.

Programming via the interface gives you far greater freedom for designing your printed pages, however, it is also a more sophisticated method and requires some experience with programming languages and printer control systems.

All programming via the interface is lost after you turn off the printer, whereas the programming carried out using the control panel is saved and stored even after you turn off the printer.

5.1 Setting the parameters through the LCD Panel

This chapter describes the handling of the operator's panel with optional display.

5.1.1 Enabling access to menu mode

The menu can be locked by default to protect it from accidental or unauthorized access. Proceed as follows to release this lock temporarily.

- 1) Switch off the printer for approx. 5 seconds.
- 2) Switch the printer on again keeping the Setup key pressed.

Calling up the menu

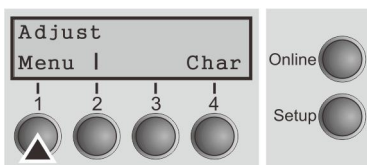

You can access the menu in the following way:

Press the Setup key. The printer switches to Setup mode. (The Setup mode can be selected both in the

Online and Offline mode)

To access the printer menu, press the key directly underneath the word Menu (1).

5.1.2 Menu configurations

Every printer is shipped with factory default settings. Basic settings such as emulation, character size, form length etc., which many applications make use of, are set. At the end of this chapter you will find a menu printout which shows you the printer's default settings.

Your printer allows you to set and use five independent menu configurations. If one of your applications, for example, requires an IBM printer while another program works better with an EPSON printer, you can set an IBM emulation configuration with the desired settings, and set the second configuration as an EPSON emulation.

The active menu is always the one you used last. When you switch on the printer for the very first time, menu no. 1 is loaded. Menu no.1 only remains active until you load another menu. The last active menu is stored even after the printer is switched off and is reloaded automatically when the printer is switched on again.

For example, to change from menu no. 1 to menu no. 3:

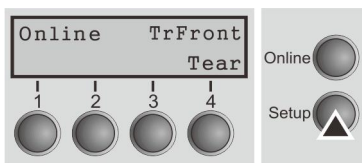

Press Setup key.

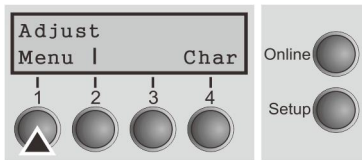

Press Menu (1) key.

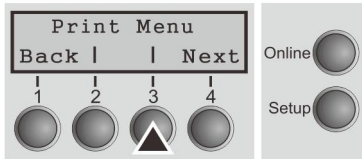

Press Menu (3) key.

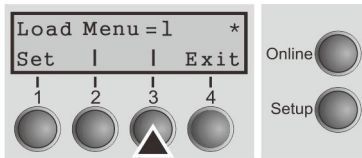

Now the following message appears in the LC display:

Now press the < (2) or > (3) key repeatedly until Load Menu=3 appears.

Then select menu no. 3 as the current setting using the Set key (1).

The currently active setting is marked with an asterisk (*).



If changing menus it is possible that the printer initializes due to different emulation settings.

Menu Printout

	Menu 1	Menu 2	Menu 3	Menu 4	Menu 5	Current
Font	Draft	Draft	Draft	Draft	Draft	Draft
CPI	10 CPI	10 CPI	10 CPI	10 CPI	10 CPI	10 CPI
LPI	6 LPI	6 LPI	6 LPI	6 LPI	6 LPI	6 LPI
Skip	0.0Inch	0.0Inch	0.0Inch	0.0Inch	0.0Inch	0.0Inch
ESCChar	ESC	ESC	ESC	ESC	ESC	ESC
Emulate	Epson LQ-2550	IBM Propr. XL24	Epson LQ-2550	Epson LQ-2550	Epson LQ-2550	Epson LQ-2550
Bidir	On	On	On	On	On	On
CG-Tab	Graphic	Graphic	Graphic	Graphic	Graphic	Graphic
CharSet	Extended	Extended	Extended	Extended	Extended	Extended
Country	E-US ASCII	Table 437	E-US ASCII	E-US ASCII	E-US ASCII	E-US ASCII
Sl.Zero	Off	Off	Off	Off	Off	Off
Auto-CR	On	On	On	On	On	On
Auto-LF	Off	Off	Off	Off	Off	Off
AutoTear	ViewTear-Off	ViewTear-Off	ViewTear-Off	ViewTear-Off	ViewTear-Off	ViewTear-Off
Width	8Inch	8Inch	8Inch	8Inch	8Inch	8Inch
LeftMrg	0/10"	0/10"	0/10"	0/10"	0/10"	0/10"
RightMrg	80/10"	80/10"	80/10"	80/10"	80/10"	80/10"
Barcode	Off	Off	Off	Off	Off	Off
Barcode	Unsecured	Unsecured	Unsecured	Unsecured	Unsecured	Unsecured
Single						
Formlen	Fanfold 12"	Fanfold 12"	Fanfold 12"	Fanfold 12"	Fanfold 12"	Fanfold 12"
FormAdj	12/72"	12/72"	12/72"	12/72"	12/72"	12/72"
TrFront	*	*	*	*	*	*
Formlen	Fanfold 12"	Fanfold 12"	Fanfold 12"	Fanfold 12"	Fanfold 12"	Fanfold 12"
FormAdj	12/72"	12/72"	12/72"	12/72"	12/72"	12/72"
TrRear						
Formlen	Fanfold 12"	Fanfold 12"	Fanfold 12"	Fanfold 12"	Fanfold 12"	Fanfold 12"
FormAdj	12/72"	12/72"	12/72"	12/72"	12/72"	12/72"
PullTr.						
Formlen	Fanfold 12"	Fanfold 12"	Fanfold 12"	Fanfold 12"	Fanfold 12"	Fanfold 12"
FormAdj	12/72"	12/72"	12/72"	12/72"	12/72"	12/72"
Interf.	Shared					
Buffer	256 KB					
CX-bid	On					
Menu	1					
TearAdj TrFront	0					
TearAdj TrRear	0					
TearAdj PullTr.	0					
Quietm.	Off					
Pap.back	normal					
APW	Off					
Sound	On					
FFmode	Off					
Wrap	On					
PLM	On					
Widthcon	Off					
Pagewid	80/10"					
Physln	0/10"					
Hvy Form	Off					
GrSpeed	normal					
Jobctl	Off					
Eject	Top					
Serial						
Baud	9600					
Format	8Bit No 1Stop					
Protocol	XON/XOFF					
DTR	DTR					
ETH-INT	OCTET 1	OCTET 2	OCTET 3	OCTET 4		
IPv4Addr	192	168	11	53		
Gateway	192	168	11	253		
Subnet	255	255	255	0		
IP Get Method	DHCP					
EthSpeed	Auto-Sense					
EthConnected	No					
Banner	Off					
MAC Adr	FF-FF-FF-FF-FF-FF					
IPv6Addr1	fe80::fdff:ffff:feff:ffff					
IPv6Addr2	::					
IPv6Addr3	::					
IPv6Addr4	::					
IPv6Addr5	::					
IPv6Addr6	::					

5.1.3 Menu handling

You can navigate in the current menu using the four function and selection keys arranged below the LC display field. Each function and parameter displayed in the LCD is executed or selected by the corresponding key below, respectively. Usually two parameter groups are combined at one level. In the following example, these are the LPI and Skip parameter groups.

If you do not wish to change one of the two parameters you can either press the Next key (to access the two following parameter groups in the menu), or you can press the Back key (to access the two previous parameter groups in the menu).

If you want to change a setting, (e.g. the line density), then press the LPI key (LPI = lines per inch) to access the actual parameter level.

The currently valid setting is marked by an asterisk (in the example below the current setting is 6 lpi). With the < and > keys you can view the other parameters available for this setting.

Example:

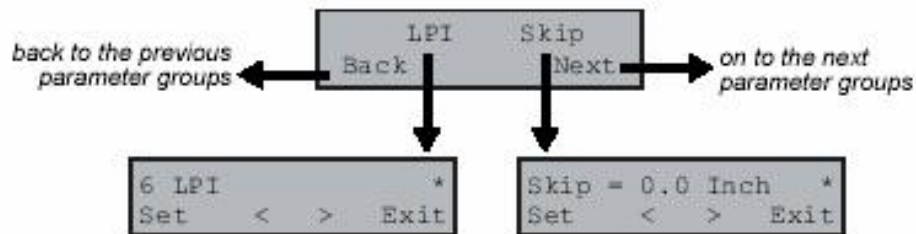

Save settings

Once the desired parameter is displayed on the LC display, you can save it by pressing the Set key. The parameter is then set and the printer automatically displays the parameter groups again. With the Exit key you can leave the sublevel without saving your changes.

5.1.4 Selecting the LC display language

This section describes how to make settings in the menu, using the selection of the national language as an example.

In this user manual all LC display messages are shown in English language. Your printer offers also the possibility to show the display messages in German, French, Italian, Spanish or Turkish language. This example shows how to change from the English language to the German language. The same procedure applies to the other languages (French, Italian, Spanish and Turkish).

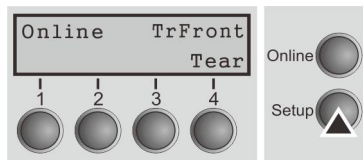

Select the Setup mode by pressing the Setup key.

i **Setup mode and Menu mode may be disabled. Hold down the Setup key while switching on the printer to enable menu mode. If you want to enable access to this mode permanently, you need to change the appropriate setting in the menu.**

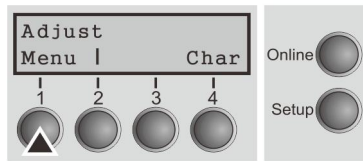

Press the next key (4) several times until the display indicates Language.

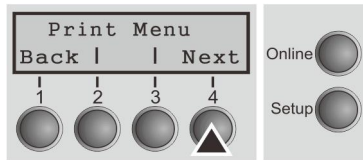

Press the Language key (3).

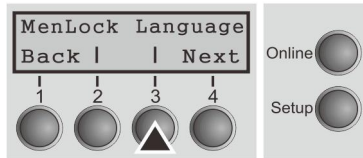

The display now changes to Parameter mode and indicates English in the top line.

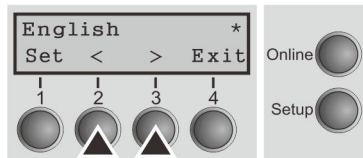

The lower line displays Set and Exit. The two arrows < (2) and > (3) represent the symbols for parameter selection (“<” indicates descending and “>” ascending). Press the < (2) or > (3) key until the desired language is displayed, in our example German.

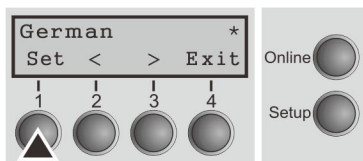

Save your selection by pressing the Set key (1). An acoustic signal verifies this action.

You can exit Parameter mode without saving a setting by pressing the Exit key (4), the old setting is retained.

After saving your setting (Set), the display in our example Ges.Men indicates the following text:

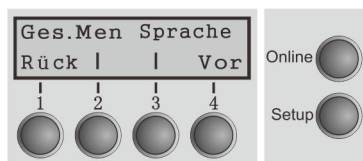

i **This setting is retained even after switching off your printer. Terminating Setup mode press either the Setup key to change into Offline mode or the Online key to change to Online mode.**

5.2 Menu structure

The menu structure of your printer may be slightly different from the example shown here, depending on the printer software.

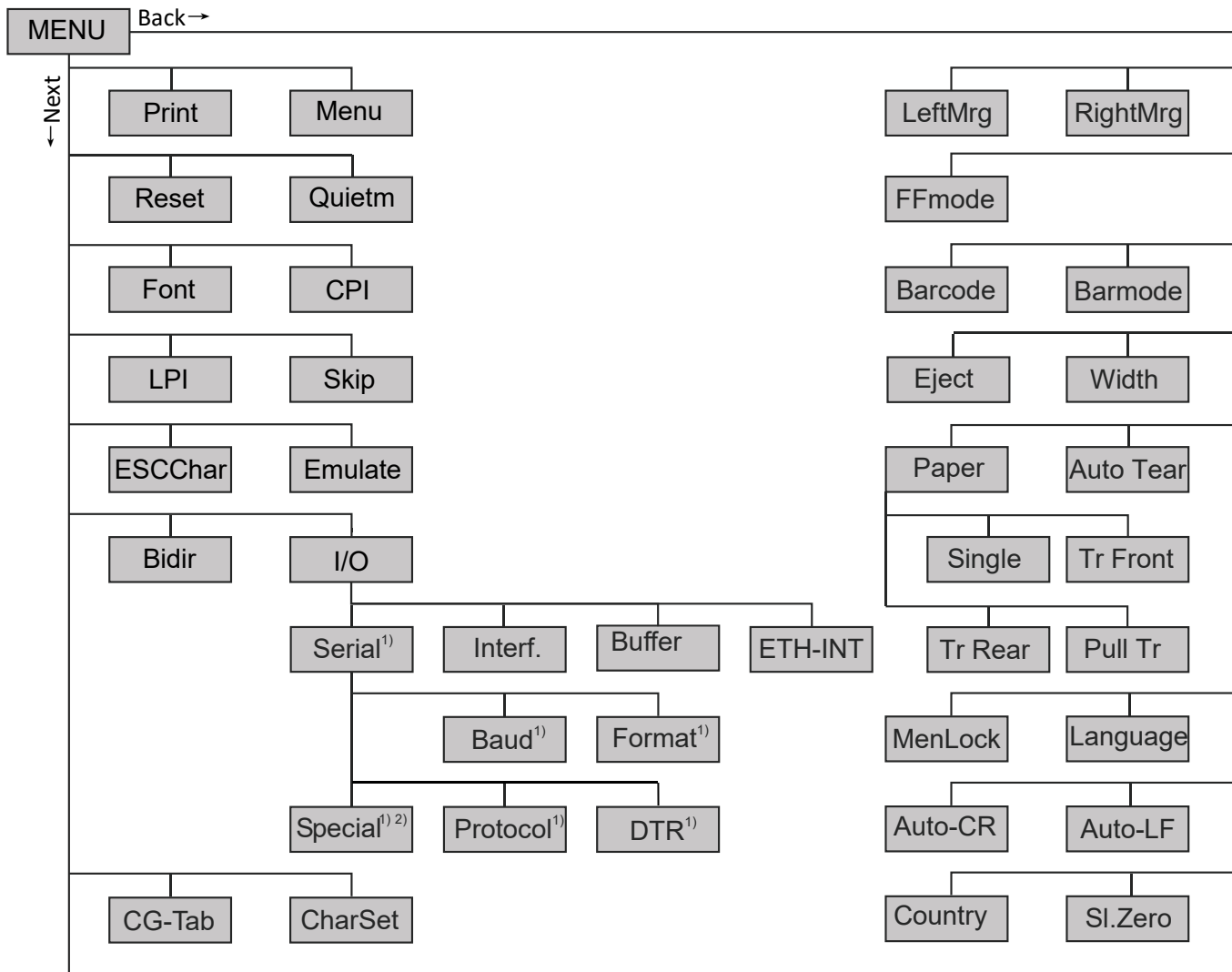

1) Only with optional serial interface

2) Only if ENQ/STX, ETX/ACK or ACK/NAK protocol is selected

5.3 Full list parameters setting

5.3.1 Menu Configuration list

Menu	Valid Settings			Function
Adjust	TOF Tear			Setting the tear position. Setting the first printing line (TOF).
Print				Print the menu settings.
Menu	<u>Load Menu=1</u> Load Menu=2 Load Menu=3 Load Menu=4 Load Menu=5			A menu is loaded, you can choose between five menus.
Reset	Reset Menu Yes No			Press the No (1) or Yes (2) key to select the desired setting. All manually altered settings in the current menu are lost when it is reset to the default settings. We therefore recommend that you print out the menu first.
Quietm	<u>Off</u> On			Switches between normal and quiet mode printing. For all printing modes, the print-out is made with the bidirectional method in quiet mode printing. In the first step the first row of pins is activated, during the second step the second row is used.
Font	HS-Draft	<u>Draft</u>	Draft Copy	This parameter selects the character style and its quality permanently.
	Roman LQ	Roman PS NLQ	Roman PS LQ	
	CourierNLQ	Sans Serif NLQ	Sans Serif LQ	
	Courier LQ	S Serif PS NLQ	S Serif PS LQ	
	Prestige NLQ	Prestige LQ	Script NLQ	
	Script LQ	OCR-B NLQ	OCR-B LQ	
	OCR-A NLQ	OCR-A LQ	Orator NLQ	
	Courier I NLQ	Courier I LQ	Orator LQ	
	Souvenir NLQ	Courier I PS NLQ	Gothic NLQ	
	Souvenir LQ	Courier I PS LQ	Gothic LQ	

Menu	Valid Settings	Function
CPI	10 CPI , 12 CPI, 15 CPI, 17.1 CPI, 20 CPI, 5 CPI, 6 CPI, 7.5 CPI, 8.6 CPI.	Sets the characters per inch (character pitch). The higher parameter the smaller character spacing.
LPI	6 LPI , 8 LPI, 12 LPI, 2 LPI, 3 LPI, 4 LPI.	Sets the lines per inch (line density). The higher parameter the smaller line spacing (random LPI can be selected via the ESC sequences).
Skip	Skip=0.0 Inch , Skip=0.5 Inch, Skip=1.0 Inch, Skip=1.5 Inch, Skip=2.0 Inch, Skip=2.5 Inch, Skip=3.0 Inch, Skip=3.5 Inch.	Skips the perforation; 7 different values (in inches) can be defined.
ESCChar	ESCChar=ESC ESCChar= ESC+\$\$	Selects the start signal for control sequences. Setting ESC: Only character Escape can be used. Setting ESC+\$\$: Character Escape or alternatively two \$ characters (\$\$) can be used.
Emulate	Epson LQ-2550 Epson LQ-2170 IBM Propr. XL24 IBM ProXL24+AGM Epson FX MTPL	Selects the emulation. When a printer understands the control set written for another printer type, it is said to emulate the other printer.
Bidir	Bidir=On Bidir=Off	Setting On: Printer prints in both directions (bidirectional). Setting Off: Printer prints only in one direction (from left to right).

Menu	Valid Settings		Function
I/O	Serial	Baud <u>Baud=9600</u> Baud=19200 Baud=600 Baud=1200 Baud=2400 Baud=4800	Selects the data transmission rate (baud rate) (baud=bit per second).
		Format <u>8Bit No 1Stop</u> 8Bit No 2Stop 8Bit Even 1Stop 8Bit Odd 1Stop 8Bit Mark 1Stop 8Bit Spc 1Stop 7Bit No 2Stop 7Bit Even 1Stop 7Bit Odd 1Stop 7Bit Even 2Stop 7Bit Odd 2Stop 7Bit Mark 1Stop 7Bit Spc 1Stop 7Bit Mark 2Stop 7Bit Spc 2Stop	This parameter serves to define the number of data bits, the parity check for received data bytes and the number of stop bits per data byte.
		Protocol <u>XON/XOFF</u> Robust XON/XOFF ENQ/STX ETX/ACK ACK/NAK	This parameter serves to select the type of protocol, i.e. a certain set of rules and procedures for ensuring error-free data exchanges between computer and printer.
		DTR <u>DTR=DTR</u> DTR=Ready	Defines the conductor to which the DTR signal is connected (DTR=Data Terminal Ready).

Menu	Valid Settings		Function
I/O	Interf.	<u>Interf.=Share</u> Interf.=Parallel Interf.=Serial	Selects the interface. Printer is configured either for parallel. Ethernet or optional serial connection or in automatic change for the parallel or the optional serial interface (Shared).
	Buffer	Buffer=0 KB Buffer=32 KB Buffer=64 KB Buffer=96 KB Buffer=128 KB Buffer=160KB Buffer=192KB Buffer=224KB <u>Buffer=256KB</u>	Selects the size of the interface buffer.
ETH-INT	IPv4Addr	Octets 1-4 0 to 255	Input of the IPv4 address of the printer This menu level offers the possibility to set the IPv4 address, which is divided into four digit groups (octet 1 to 4). The IPv6 IP address settings are executed fully automatic.
	Gateway	Octets 1-4 0 to 255	Input of the Gateway address of the printer.
	Subnet	Octets 1-4 0 to 255	Input of the Subnet mask address of the printer.
	IP Get M	<u>DHCP</u> BOOTP Static	Selects the way of administrating the IP address.
	Banner	<u>Off</u> On	Specifies whether a banner page is to be printed out, when using the LPD/LPR protocol.
	EthSpeed	<u>Auto-Sense</u>	The transmission speed is detected automatically.
		10Mbit Half	Sets the transmission speed to 10 MBit half duplex per second.
		10Mbit Full	Sets the transmission speed to 10 MBit full duplex per second.
	100Mbit Half	Sets the transmission speed to 100 MBit half duplex per second.	
	100Mbit Full	Sets the transmission speed to 100 MBit full duplex per second.	

Menu	Valid Settings			Function
CG-Tab	<u>CG-Tab=Graphic</u> CG-Tab=DLL CG-Tab=Italic			Only available for Epson LQ-2550/LQ-2170 emulation. Either the Epson character set Italics or the IBM graphics character set or a DLL (download) character set, as defined before, can be activated in the code range from hex. A0 to hex. FE.
CharSet	<u>Extended</u> Standard			Selects the IBM standard characters or the extended IBM characters.
Country	E-US ASCII	E-France	E-German	Selects the national character set. These character sets can be used according to the selected emulation.
	E-UK	E-Denmark I	E-Sweden	
	E-Italy	E-Spain I	E-Japan	
	E-Norway	E-Denmark II	E-Spain II	
	E-L.America	E-Korea	E-Legal	
	ISO8859-1	ISO8859-1 SAP	ISO8859-2	
	ISO8859-5	ISO8859-7	ISO8859-9	
	ISO8859-15	ELOT-928	BRASCII	
	Abicomp	Roman8	US-ASCII	
	UK ASCII	French	German	
	Italian	Swedish	Norwegian	
	Spanish	Portuguese	Greek DEC	
	Cro-ASCII	Coax/Twinax	Table 437	
	New-437	Table 737	775 Baltic	
	Table 850	New-Dig 850	Table 851	
	Table 852	Tarama	Table 857	
	Table 858	Table 860	Old-Code 860	
	Table 861	Table 863	Flarro 863	
	Table 865	865 Hebrew	Table 866	
	866 Bulgaria	866 Ukraine	866 Kazakhst.	
	Kamenicky	Mazovia	Siemens Turk.	
	DEC Turkish	Table 1250	Table 1251	
	Table 1252	Table 1253	Table 1254	
	Table 1257			
SI.Zero	<u>SI.Zero=Off</u> SI.Zero=On			Selects if normal zero (0) or the slashed zero (Ø) is printed.
AutoCR	<u>Auto-CR=On</u> Auto-CR=Off			Switches the automatic carriage return on or off after receiving the signal LF (line feed).

Menu	Valid Settings	Function
AutoLF	<u>Auto LF=Off</u> Auto LF=On	Switches the automatic line feed (LF) on or off after receiving the signal CR (carriage return).
Menlock	<u>Menlock=Off</u> Menlock=Menu Menlock=All	<p>With MenLock=Off, all functions and settings are accessible without restriction in Online, Offline and Setup mode.</p> <p>If MenLock=Menu is activated, all functions and settings are still accessible in Online and Offline mode, however, in Setup mode you can only access the parameter groups Adjust (setting the print head gap [Head], top of form [TOF] and tear position [Tear]), Paperway (setting the paper path), Font (setting the font) and the character spacing (CPI), while access to Menu mode (Menu key) is disabled.</p> <p>If you select MenLock=All, you can access the Online/Offline, Load/Park, Paper and Paper Feed (LineFeed/Form Feed, /) functions in Online and Offline mode while Setup mode is disabled.</p> <p>In this case, the Setup menu can only be called up by holding the key Setup while switching on the printer.</p>
Language	<u>English</u> German French Italian Spanish Turkish	The menu can be shown in six languages.
Paper	Single TrFront TrRear PullTr	Selects the paper parameters Formlen (form length), FormAdj (first printing position/TOF) separately for each paper source in the current menu.

Menu	Valid Settings		Function
Formlen	Lines	=6 – 132 Default 6LPI = 66 Single:3—22 inches TrFront、 TrRear 、 PullTr: 1—22 inches	Sets the form length via line formats. Please note that the adjustment in Lines depends on the selected LPI. For example 8 LPI at a selected line number of 96 lines results in a form length of 12 inches (96lines/[8lines/inch]) = 12 inches. The selectable range is between 3 and 21 inches, i.e. for 2 LPI from 6 to 42 lines and for 12 LPI from 24 to 262 lines. If the form length is set it will not be changed by changing the LPI later on.
	Standard	No format DIN A3 (420 mm) DIN A4 (297 mm) DIN A5 (210 mm) DIN B5 (250 mm) DIN B6 (176 mm) DIN C6 (162 mm) Executive 10.5" <u>Letter 11"</u> Fanfold 12" Legal 14"	Selects the form length by standard formats. Using Standard, different paper formats can be selected directly, e.g. DIN A4, Legal, Letter. The Menu indicates No format if a value is selected by the Line function or ESC sequences, which does not correspond to a standard format.
FormAdj	FormAdj=0 -220/72" Default 12/72"		Sets the first print position of a form in n/72 inch, separately adjustable for each paper path.

Menu	Valid Settings	Function
Autotear	<u>ViewTear =Off</u> View=1s/3s/6s Tear=1s/3s/6s Tear at TOF	<p>The auto tear function or the auto view function can be selected as desired.</p> <p>When auto view is switched on, the last printed text is visible. As soon as data is received the paper moves to the “normal” print position. After printing the printer waits for the given interval to bring the paper once more to the auto view position.</p> <p>The paper is in the tear off position when auto tear is switched on, the perforation of the positioned at the tear off edge of the printer. If data is received, the paper returns to the normal print position. After printing, the printer waits for the given interval to bring the paper once more to the tear off position. If the tear off edge does is not aligned with the perforation of the paper then this can be corrected.</p>
Width	<u>Width=13.6Inch</u> Width=8Inch Width=13.2Inch	<p>Selects the line length in inches. With the setting of 8 Inch, the printer operates like a printer with a width of only 8 inches.</p>
Eject	<u>Eject=Top</u> Eject=Front	<p>This is valid for single sheet mode only. It controls the exit direction of the friction sheet paper.</p>
Barcode	<u>Barcode=Off</u> Barcode=On	<p>With this function selected it is possible to print different barcodes and LCP (Large Character Printing).</p>
Barmode	<u>Unsecured</u> Secured	<p>Allows printing of normal characters on the left and right of the barcode.</p>
FFmode	<u>FFmode=Off</u> FFmode=On	<p>Specifies whether a form feed is to be performed when the paper reaches the top print line.</p>
LeftMrg	Wide: LeftMrg= <u>0</u> - 134/10” Narrow: LeftMrg= <u>0</u> - 78/10”	<p>The left print margin can be set to a fixed value.</p>
RightMrg	Wide: RightMrg=2 - <u>136</u> /10” Narrow: RightMrg=2 - <u>80</u> /10”	<p>The right print margin can be set to a fixed value.</p>

5.3.2 Advanced Menu

Advanced Menu	Valid Settings		Function
ASCII80	8 inch wide print of test pattern		To check operational readiness, your printer contains a self-test routine which allows testing of the printer configuration, the print quality and correct operation of your printer.
ASCII136	13.6 inch wide print of test pattern (only 2610)		
H-Dump			With the interface test(Hex-Dump/H-Dump) you can test data transmission from the computer to the printer. During this test, the data from the computer is printed out in two columns. The text in the left column is printed in hexadecimal format and in the right column in ASCII format.
Formlen	<u>12"</u> 11"		The Formlen function allows you to set the basic (default) form length to meet your requirements. 11 inches are common in the USA, as opposed to 12 inches in Europe.
APW	<u>APW=Off</u> APW=On		Automatic paper width recognition. If set to On, the printout outside of actual loaded paper is suppressed.
Paphand	Physlm	Physlm= <u>0</u> - 30/10"	Permanent (physical) setting of the left margin. This parameter cannot be changed by emulation dependent margin settings. Margin setting values entered by ESC sequences are added to the Physlm.
	PLM	<u>PLM=On</u> PLM=Off	Parameter "PLM". This item's full name is Paper Load Mode. It is located beneath the already existing menu item "Paphand" (Paper Handling). This setting enables (on) / disables (off) a horizontal carriage movement in order to flatten the paper so it finds its way into the upper friction. However the movement is determined by the menu items Pagewid & Widthcon. If Widthcon = Off Narrow: The movement of carriage goes all the way = 8"

			<p>Wide: The movement of carriage goes all the way = 13.6"</p> <p>If Widthcon = On</p> <p>Narrow/Wide: The movement of carriage goes rightmost to Pagewid Position</p> <p>This function is ON by default and is valid for Rear Tractor only.</p>
	Pagewid	<p>2610+:Pagewid=20—<u>136</u>/10"</p> <p>2600+: Pagewid=20—<u>80</u>/10"</p>	<p>Parameter "Pagewid". This item's full name is Pagewidth.</p> <p>It is located beneath the already existing menu item "Paphand" (Paper Handling).</p> <p>This setting tells the printer logic the width of the installed paper and is valid for all paper ways.</p> <p>By default this parameter is maximum width.</p> <p>2600+: 80 Characters (80/10")</p> <p>2610+: 136 Characters (136/10")</p> <p>The value can be changed in 1/10" in a range between 20 and 136 (80).</p>
	Widthcon	<p><u>Widthcon=Off</u></p> <p>Widthcon=On</p>	<p>Parameter "Widthcon". This item's full name is Width Control.</p> <p>It is located beneath the already existing menu item "Paphand" (Paper Handling).</p> <p>This setting enables (on) / disables (off) the possibility to define the position of the carriage during loading & ejecting paper.</p> <p>If Off</p> <p>2600+: the carriage's position is 4"</p> <p>2610+: the carriage's position is 5.3"</p> <p>If On</p> <p>2600+/2610+:Half of Value defined in Pagewid</p> <p>This function is OFF by default and is valid for all paper ways.</p>
CX-bid	<p><u>CX-bid=ON</u></p> <p>CX-bid=OFF</p>		<p>CX-bid=ON sets the parallel interface of the printer to bidirectional mode (IEEE 1284, Nibble mode), e.g. for Windows Plug & Play.</p> <p>CX-bid=OFF sets the interface to compatibility mode in order to ensure reliable operation with special external boxes.</p>

Wrap	<u>Wrap=On</u> Wrap=Off	Wrap=On: If more characters than can be printed are transmitted per line, the characters which cannot be printed on this line are printed at the beginning of next line. Wrap=Off: If more characters than can be printed are transmitted per line, the characters which cannot be printed on this line are cut off.
Sound	<u>Sound=On</u> Sound=Off	When Sound=On, a beep is generated every second to notify that paper is empty.
Pap.back	<u>Pap.back=normal</u> Pap.back=dark	Pap.back=normal is the standard for normal paper. Pap.back=dark can be set to process paper with a grey back. Paper with a completely black back side cannot be used if the ink is carbon-based. However, the printer can handle aniline-based black paper (undefined colors).
Hvy Form	HvyForm=ON <u>HvyForm=OFF</u>	If you set HvyForm=ON, the printer prints the same line twice at double strike. This setting ensures that copy paper produces optimum results.
SerialN	factory set	With the SerialN function you have the possibility to change the 12 digit serial number of the printer. The number can be written with any ASCII character between hex 20 and hex 7E.
AssetN	10 digits empty	With the AssetN function you have the possibility to change the 10 digit asset number of the printer. The number can be written with any ASCII character between hex 20 and hex 7E.
GrSpeed	<u>GrSpeed=Normal</u> GrSpeed=High	This parameter allows improved Graphic Speed independently to the driver. It affects only the print speed of graphic printouts at 180 x 180 dpi.
FL-Ctrl	<u>FL-Ctrl= System</u> FL-Ctrl= Ignore	If set to "Ignore", any command to set the form length is ignored in all emulations, so that only the form length set in the printer menu is valid.
Jobcntl	Jobcntl=On <u>Jobcntl=Off</u>	This parameter activates the printer language PJI (Printer Job Language) in connection with the internal Ethernet interface (ETH-INT) or the external TallyCom III interface (ETH-EXT).

5.4 Display messages

If the printer detects an internal fault or user error or if it expects you to do something, a message will appear in the LC display.

It also displays the status during an operation (e.g. **Initializing**). Below you will find a list of messages with brief descriptions of each message.

Messages LCD Panel

LCD Messages	Meaning
Eject error	The printer cannot eject the paper/advance it to park position.
Hardware Alarm	Internal hardware error, contact your dealer or service technician.
Head hot	The print head is too hot. The printer will reduce its print speed.
Initializing	This message appears during the printer's initializing phase after switching on the printer.
Load error	The printer fails to load the paper.
Loading default	Factory defined parameters will be reloaded in all available menus after switching on the printer.
Load paper from	The printer has detected paper end during operation/printer was switched on with no paper loaded.
Parity error	A parity error during data transmission is indicated.
Park position	Printer was switched on with no paper loaded.
Press any key	The user is requested to press any key.
Selftest	After power-on, the printer executes a short hardware self-test.
Tear Paper off	The user is requested to tear off paper which has been advanced to the tear.
Switch Paper Lever	Choose correct paper path. Turn paper lever

5.5 USB host interface

The printer is equipped with a USB host interface. A standard USB memory device can be plugged into this interface and can then be used for firmware download and config file up- and download. The USB device must be formatted with FAT16 or FAT32 file system, other formats like NTFS are not supported. It is strongly recommended to use an empty and newly formatted device; otherwise the data transfer may not work. The firmware or config files for download must always be located in the root directory! The format of the config files is the same that is used when you up-/download the printer configuration via the webpanel or via the config tool.

5.5.1 Firmware Download

This function will be activated by pressing key 1 during power on. The display now shows "USBH firm. down." and "Insert USB stick". After a USB stick was connected, the printer will search the root directory for a file with the extension *.mot. If more than one file with this extension is found, the first one will be used. If no file was found, the display will show "no file found". After the download was completed, the printer will reboot.

5.5.2 Configuration File Upload

This function will be activated by pressing key 2 during power on. The display will now show "upload cfg file." and "Insert USB stick". After a USB stick was connected, the printer will write the config file (extension *.cfg) to the USB stick. The file name is the same as the firmware ID number. During the write time, the display will show "please wait". If the same file already exists, the display will show "cfg file exists" and "please delete it". Then the user should delete the file and try it again. After the upload was completed, the printer will reboot.

5.5.3 Configuration File Download

The function will be activated by pressing key 3 during power on. The display will now show "USBH cfg down." and "Insert USB stick". After a USB stick was connected, the printer will search the root directory for a file with the extension *.cfg. If more than one file with this extension is found, the first one will be used. If no file was found, the display will show "no file found". You then have the chance to remove the USB stick and try again, maybe with a different device. After the download was completed, the printer will reboot.

6 Web Panel and Internal Ethernet Interface

6.1 Summary

6.1.1 Introduction

It is assumed you have the following:

- A working knowledge of your network system and related utilities.
- Access to the supervisor or administrator account as a network administrator.

6.1.2 Supported Environments

The built-in network interface supports the following platforms and protocols:

- Microsoft® Windows® NT 4.0, 2000, XP,7,8.1/10, Server 2003/2008/2012/2016
- Linux – Red Hat®, SuSE®
- Unix® – Sun Solaris®, HP-UX®, IBM AIX®
- TCP/IP, HTTP, LPR/LPD

6.1.3 Network Interface and Cabling

The printer requires:

- Ethernet 10Base-TX or 100Base-TX interface.
- Category 5e or 6 Ethernet cable with RJ-45 socket connectors.

6.1.4 Connecting the Printer

Connect the Ethernet cable to the network interface port RJ-45 connector on the rear center of the printer.

6.1.5 Network Interface Status

There are two status lights (LEDs) next to the RJ-45 connector on the rear panel.

- Right green light (Link Status) is solid: This shows the printer is connected to the network.
- Right green light is blinking: Shows network activity.
- Left yellow light (Duplex Status) is solid: Shows network interface is in full duplex mode.

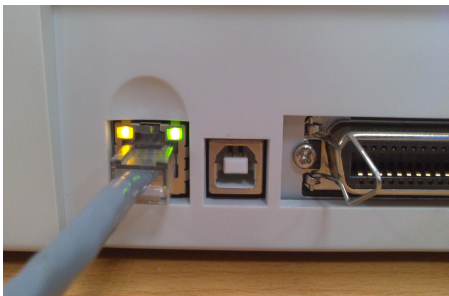

Unless the link status light is green, the printer will not be able to connect to the Network.

6.1.6 IPv6 Functionality

The printer is now supporting IPv6 as a supplement for the still existing IPv4 functionality. The IPv6 address settings are executed fully automatic. There is no need and no option for configuring the settings. The IPv6 addresses will be shown on the status page and print server status frame.

6.2 IP Configuration

6.2.1 Network IP Configuration

The network interface of the printer requires an IP address.

There are several ways to assign an IP address to the printer:

- DHCP (A Dynamic Host Configuration Protocol server assigned IP address.)
- Static (An IP address obtained from your network administrator added to the printer manually.)
- BOOTP (Bootstrap Protocol server assigned IP address.)

6.2.2 Assigning the IP Address

If the printer menu is locked, please see the [5.1.1](#).

1. Automatic DHCP IP address assignment:

- Press <Setup>, then <Menu>.
- Press <Next> until the I/O selection appears. Select <I/O>.
- Press <Next> until the ETH-INT selection appears. Select <ETH-INT>.
- Press <Next> until the IP Get M selection appears. Select <IP Get M> Select <DHCP>.
- Verify that your printer was assigned an IP address by printing the “Current Settings” configuration page or in the operator panel menu.



- 1) At power-up, the printer network interface broadcasts a DHCP request for an IP address. If a DHCP server is present, the request will be processed, and an IP address will be returned to the printer network interface. Upon receipt of the IP address, the printer accepts and uses this new IP address (and subnet mask, and default gateway, if any).
- 2) Once an IP address has been assigned, the printer network interface will no longer broadcast DHCP requests. The printer will broadcast a DHCP request each time you turn on the printer.
- 3) The DHCP server may grant a temporary IP address, called a temporary lease or temporary reservation, which expires later, or may grant a permanent or unlimited time lease or reservation, which does not expire.
- 4) Devices such as the printer that are granted a temporary lease will be notified before the lease expires and asked if they would like to extend the lease. The printer network interface will continue extending its lease indefinitely (unless prohibited by your DHCP server configuration), and thus maintain a consistent IP address.

- 5) If the printer is not turned on or is not connected to the network when the DHCP server is sending requests to extend the lease, the lease will not be extended. The DHCP server will cancel the lease and may assign the IP address to another device. Therefore, it is highly recommended to explicitly specify the printer lease as permanent or unlimited in your DHCP server configuration.

2. Static assignment using the operator panel:

- Press < Setup >, then < Menu >.
- Press < Next > until the I/O selection appears. Select < I/O >.
- Press < Next > until the ETH-INT selection appears. Select < ETH-INT >, then < IP Addr >
- Enter the value for Octet 1 by pressing < OCTET 1 >. Use the forward and backward arrows to increment/decrement the number. When finished with each entry press < Set > which will set the currently displayed value. To exit out without changing the value press < Exit >. Enter the Octet 2 value in the same way, pressing < OCTET 2 >. To get to Octet 3 and Octet 4, select < Next > and then select <OCTET 3> and < OCTET 4 >.
- Enter the default Gateway and Subnet mask in the same way. < Gateway > is available from the screen you are returned to. Press < Next > to select < Subnet >.
- Enter the IP address get method under the selection <IP Get M>. Select <Static>.

3. BOOTP IP address assignment:

- Press <Setup>, then <Menu>.
- Press <Next> until the I/O selection appears. Select <I/O>.
- Press <Next> until the ETH-INT selection appears. Select <ETH-INT>.
- Press <Next> until the IP Get M selection appears. Select <IP Get M> Select <BOOTP>
- Obtain the Ethernet MAC address by printing the “Current Settings” configuration page, Turn off printer.
- Configure your BOOTP server with desired IP address and MAC address.
- Turn on printer.
- Verify that the printer network interface received an IP address by printing the “Current Settings” configuration page or in the operator panel menu.

6.3 WebPanel

6.3.1 Introduction

WebPanel is an intuitive browser interface that allows you to remotely manage your network attached printer. From WebPanel, you can do virtually everything you can do from the printer's control panel.

In addition, WebPanel provides full access to all of the TallyCom networking features. Before using WebPanel, you must configure your printer with an IP address, using one of the three methods discussed in the Assigning the IP Address section above.



The screenshots that are used in this document to demonstrate the functionality may vary depending on the printer model.

6.3.2 Web Browser

WebPanel is accessed from the printer through a web browser, i.e. Internet Explorer, Firefox, etc. The browser needs to be configured with cache and history empty, and the browser set up to check for new pages every time, to insure that connections to WebPanel will produce the latest data.

WebPanel does not work through a proxy server. Therefore, the web browser must be setup to NOT use the Proxy Server for local IP addresses.

Disclaimer: Dascom WebPanel runs in conjunction with third party software, notably web browsers, which are designed to run independently of the Dascom software. Dascom cannot control the third party output or how it behaves from release to release. The above browser versions have been tested with WebPanel and while there is full functionality, there will undoubtedly be visual differences and anomalies between products and versions with which Dascom has no control.

6.3.3 Access to WebPanel

Once an IP address has been set up, you can access WebPanel by typing the printer's IP address into your browser address box.

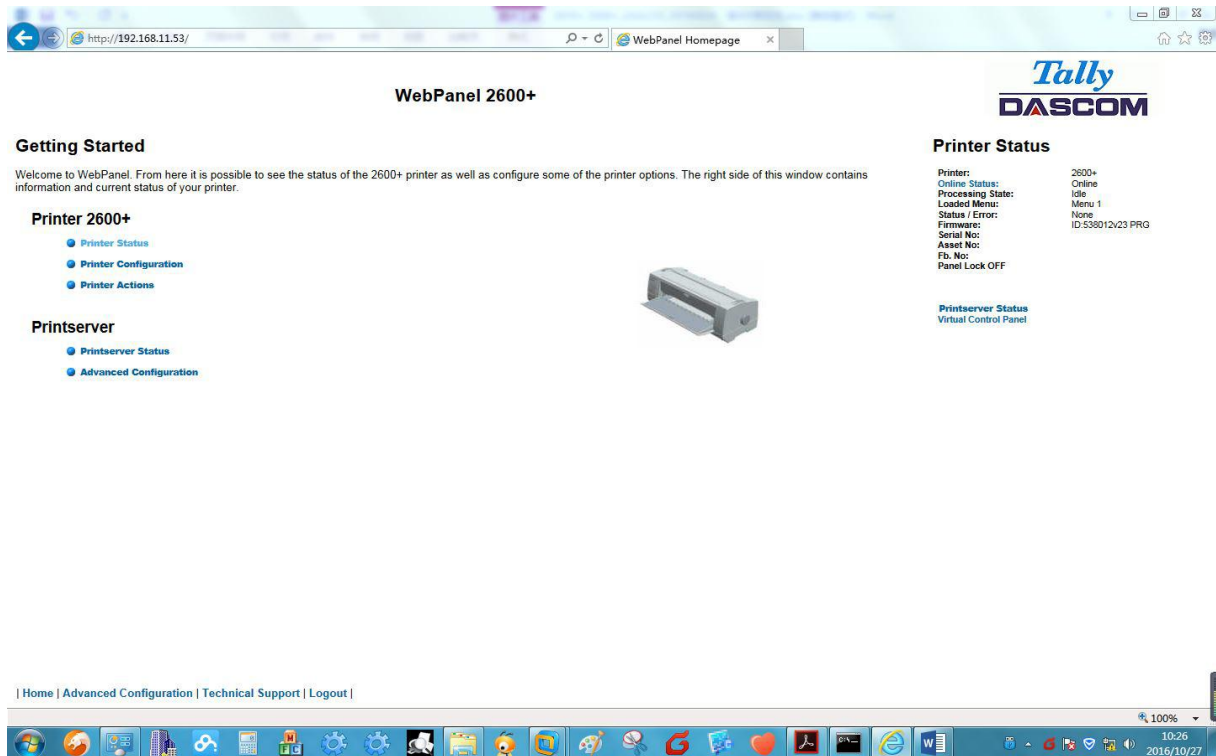

The current status of your printer is displayed on the right hand side of the screen. This is refreshed every 20 seconds, whenever you refresh the page or click Printer Status. The left side allows you to query the printer, configure it and access network options.



If you try to access the printer after power on the printer it may last up to one minute until the printer is visible in the network.

6.3.4 Access to Config Tool

The software interface for the Config Tool is shown as below. Click “Connect” to select the related interface. (After the Configuration Tool is connected, the operation interface is similar to the WebPanel, thus the operation instruction not be started again).



6.3.5 Printer Status

Selecting this option refreshes the status display. Displayed on this page are:

- Processing state
- Loaded menu
- Error state
- Firmware level
- Serial number
- Asset number
- Panel lock status

Options to change the Online / Offline state, network configuration and the virtual control panel for your printer are all accessed from this page.

6.3.6 Printer Configuration

Selecting this option allows you to configure specific parameters in the printer. When one of these menu options is selected, a new page will load showing the options which can be viewed or modified.

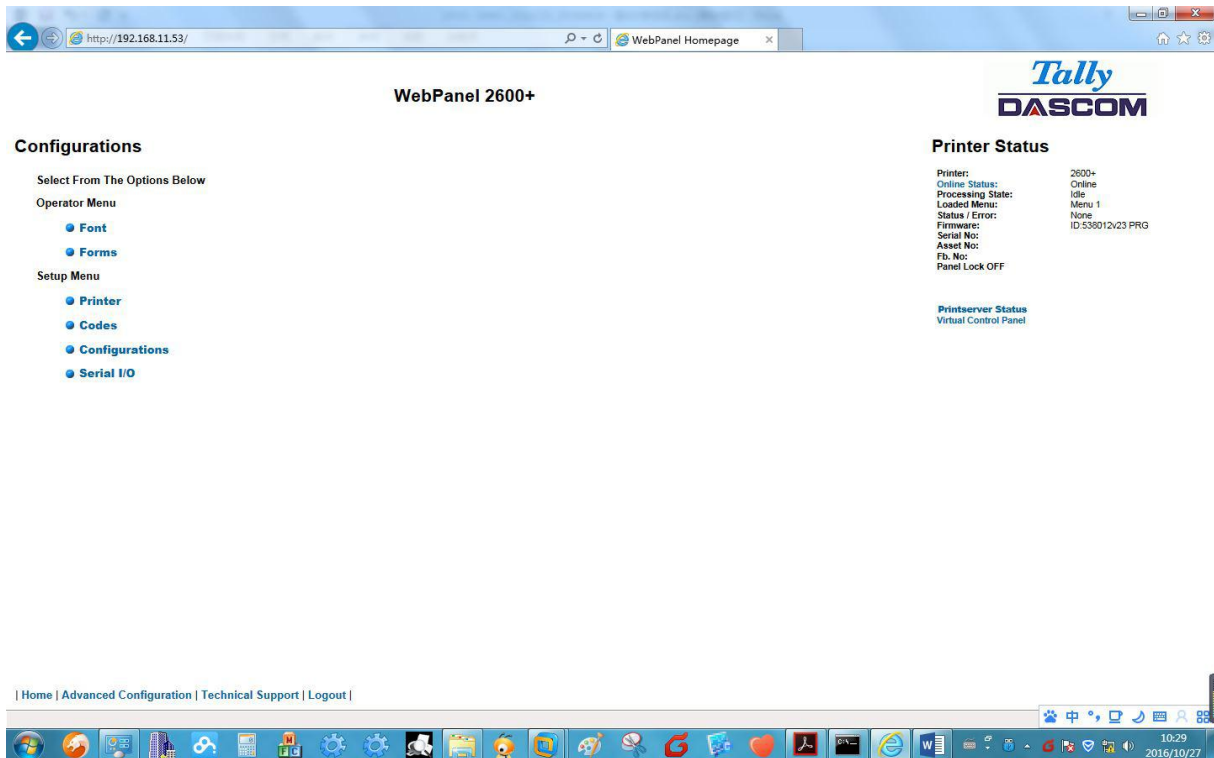

Example 1

Change the dropdown menu option.

In this example, we are modifying the selected font to a different font. Select “Font”. A new page appears.

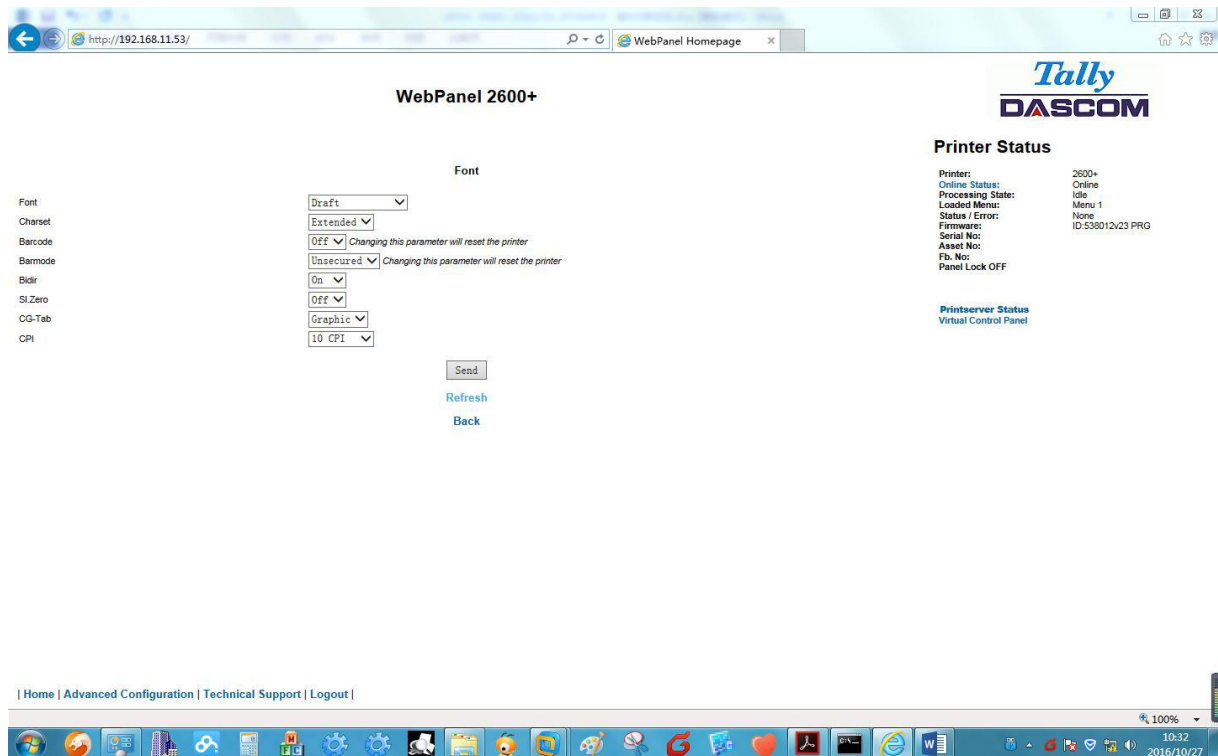

Select the Font dropdown menu and choose the new font. Select “Send”.



- 1) Changes are not applied until “Send” is selected.
- 2) To reset the changed value to the prior value, select “Refresh” instead of “Send”.
- 3) To return to the prior page without applying the change, select “Back”.

Example 2

Change an entered value menu option.

In this example, we are modifying the selected form length to a different form length. Select “Forms”. A new page appears:

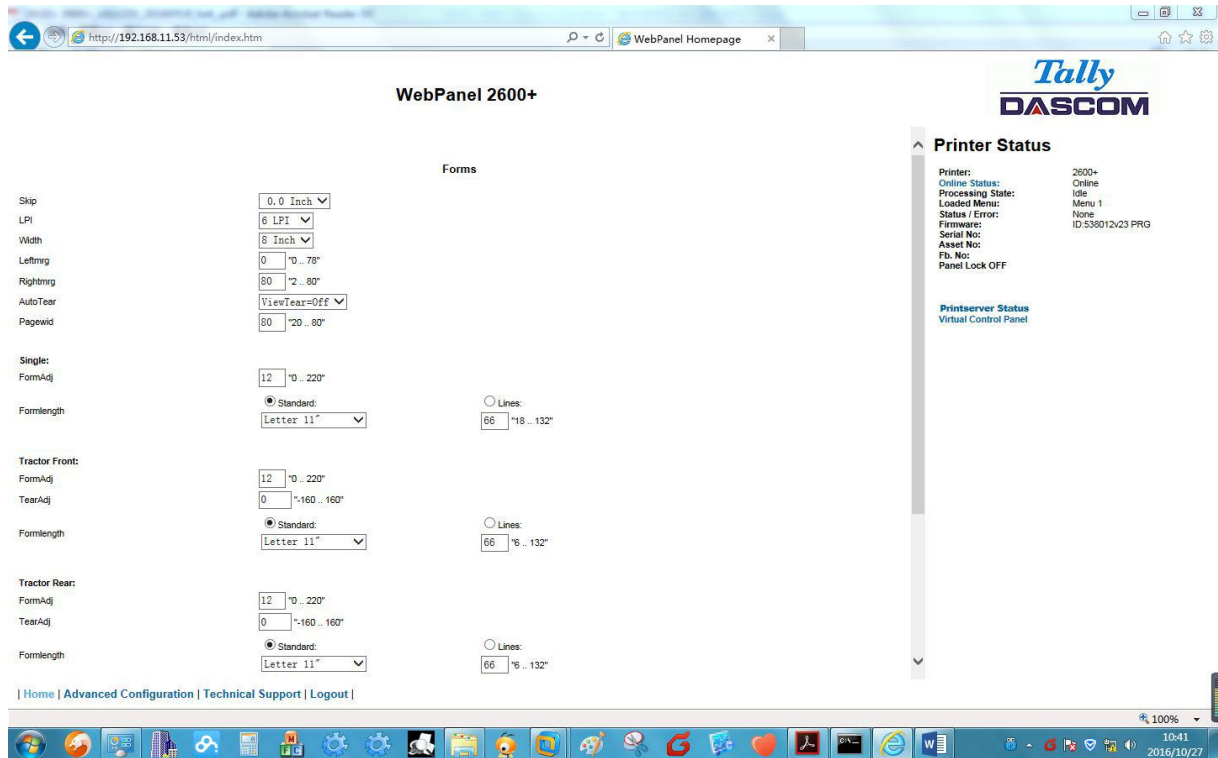

Select the Form Length field by highlighting the contents of the box and enter the new form length.

The acceptable parameters are listed to the right of the field. Select “Send”.



- 1) Changes are not applied until “Send” is selected.
- 2) If the entered value is out of range of the acceptable parameters, the previous value will be re-instated.
- 3) To reset the changed value to the prior value, select “Refresh” instead of “Send”. To return to the prior page without applying the change, select “Back”.
- 4) The default name is “conf.cfg”, but it can be renamed. Save the file to disk. This will allow it to be transferred to other printers using the “Send Configuration To Printer” option on the actions web page.

6.3.7 Printer Actions

Selecting the Printer Actions link will produce a page with a list of actions that can be performed on the printer.

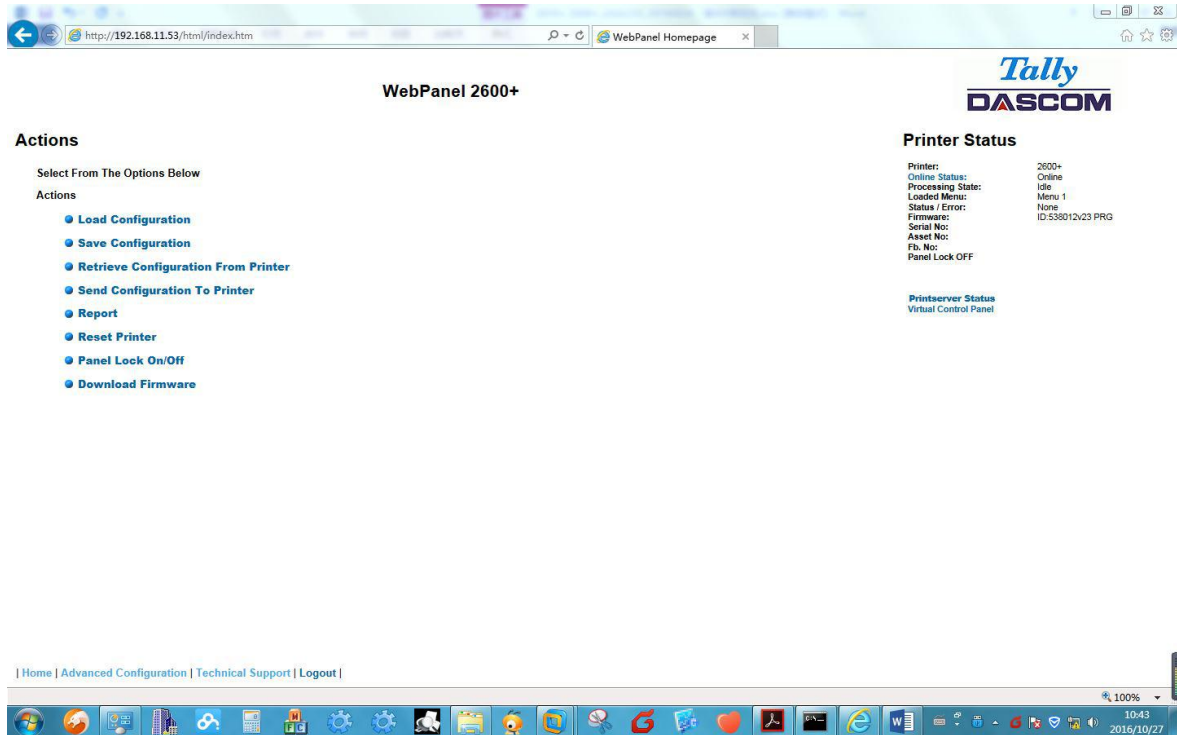

6.3.8 Load Configuration

Loads the settings stored in a menu into the printer as the current settings. When the Load Configuration link is selected, the following page will be displayed:

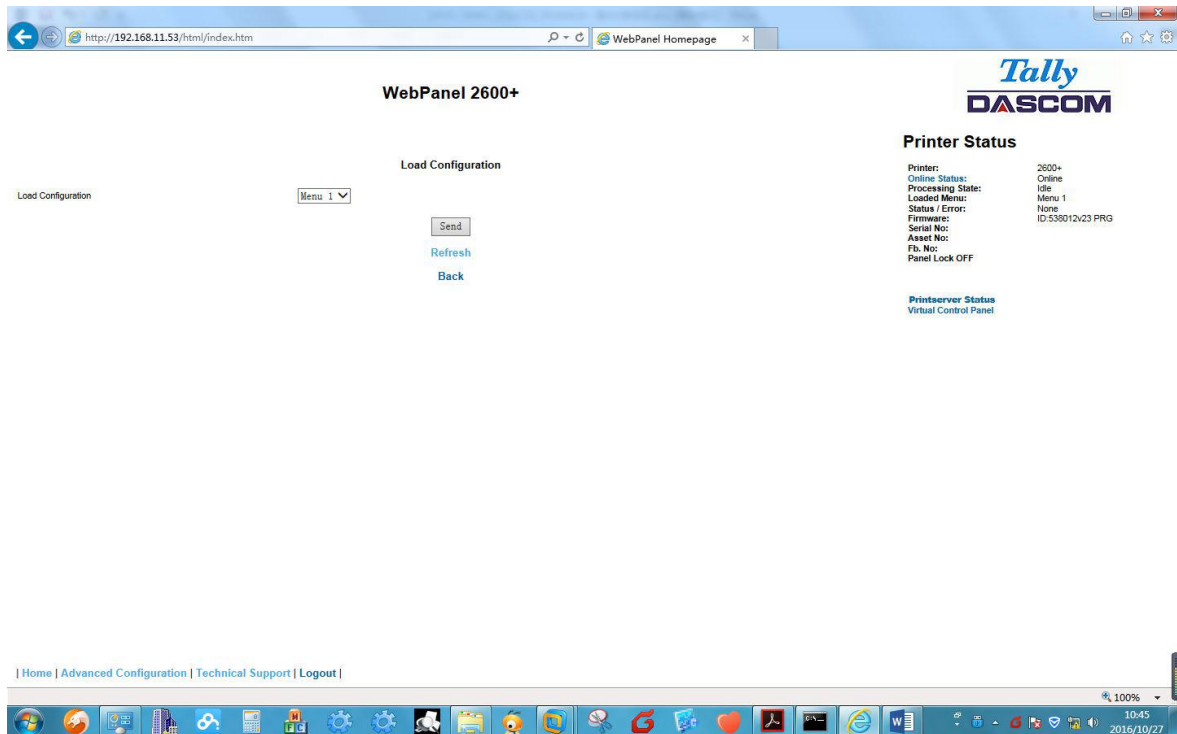

Select a menu and confirm your selection by selecting the Send button.

6.3.9 Save Configuration

You can save selected printer settings in up to 5 independent menus.

When the Save Configuration link is selected, the following page will be displayed:

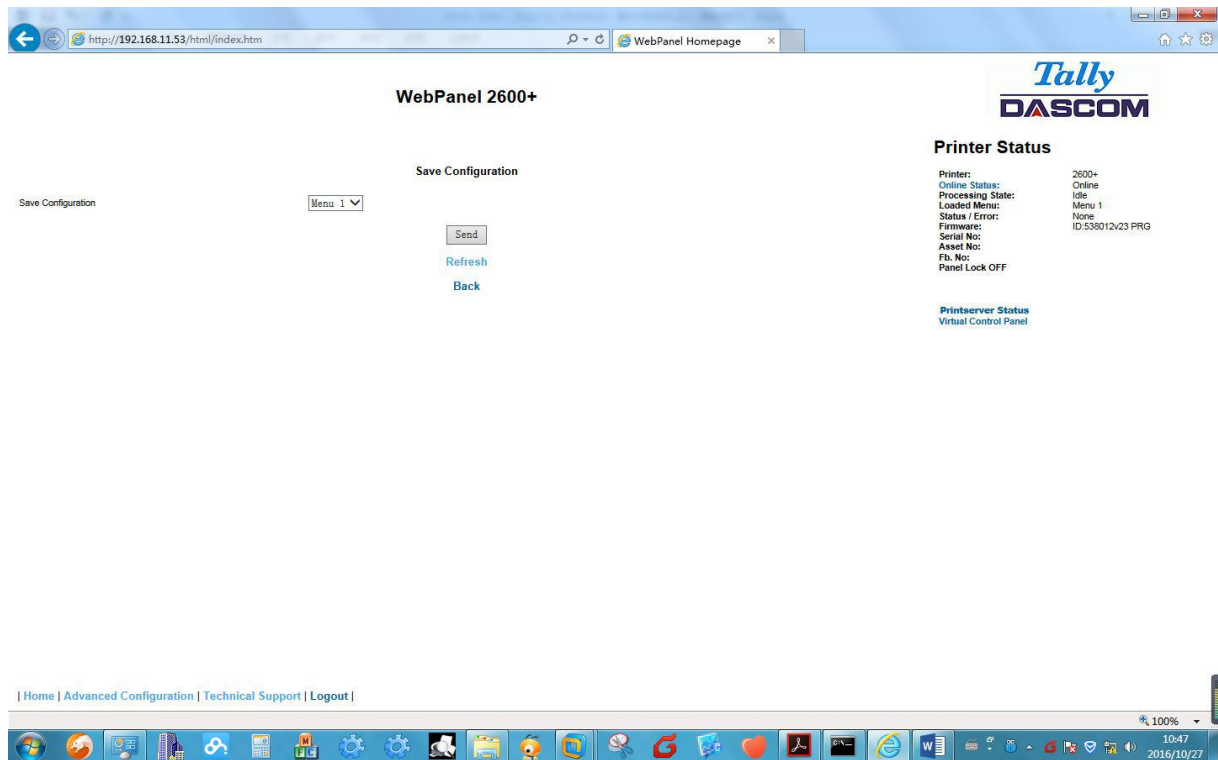

Select a menu. Select send.

6.3.10 Retrieve Configuration From Printer

Selecting this option will save all the printer settings of all menus in a file. Uploading this file to other printers will clone the printer menu settings to the other printer.

When this option is selected, the following will appear (note that the actual image will be browser specific):

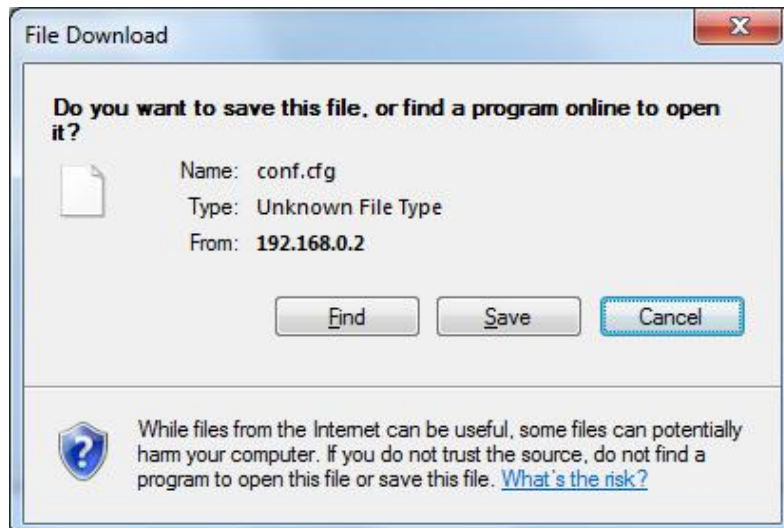

6.3.11 Send Configuration to Printer

Selecting this option will upload a Configuration File of another printer (see “Retrieve Configuration From Printer”). The complete configuration of this source printer will be transferred to your printer.

To upload the configuration file, first click “Send Configuration To Printer”. The following page will be displayed:

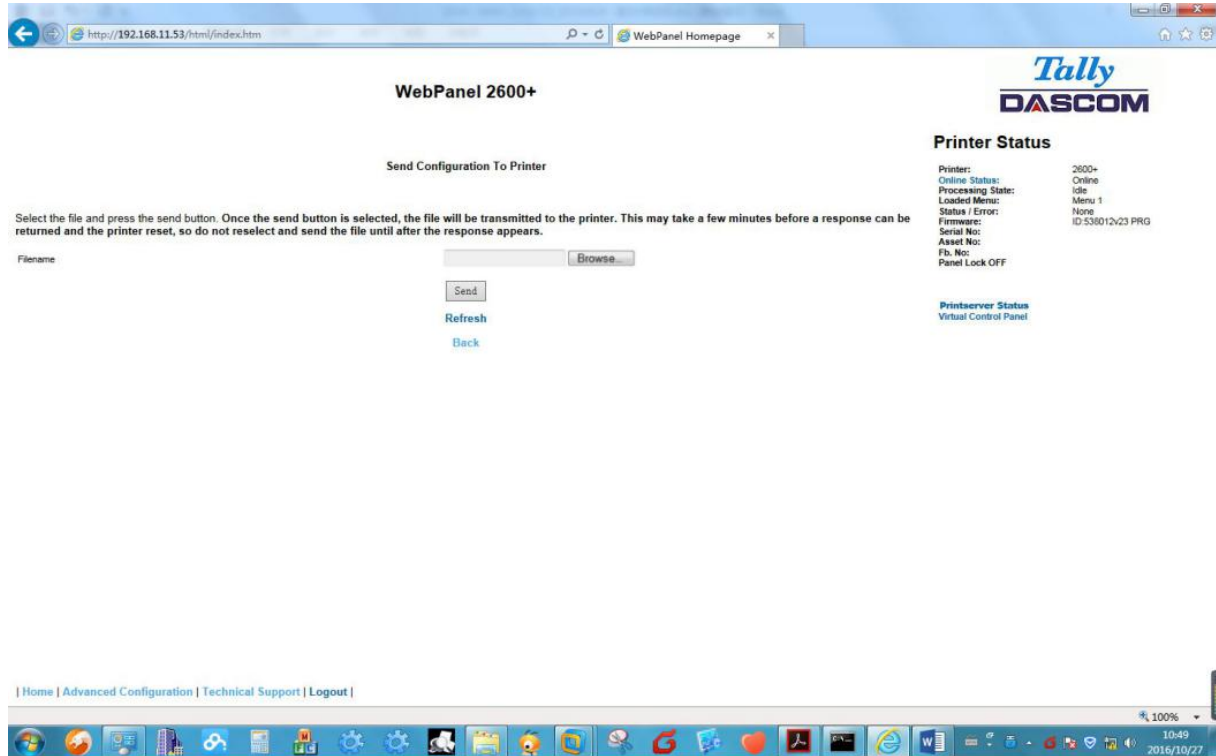

Tally Dascom 2600+/2610+

Use the “Browse” button to find the file to upload. Once the file is selected, click on the “Send” button. It is important to note the warning on this page. There is some delay while the file is transmitted so it is important not to resend or click on the “Send” button until the process is complete.

If the process is successful, the printer will reboot and the following page will be displayed:

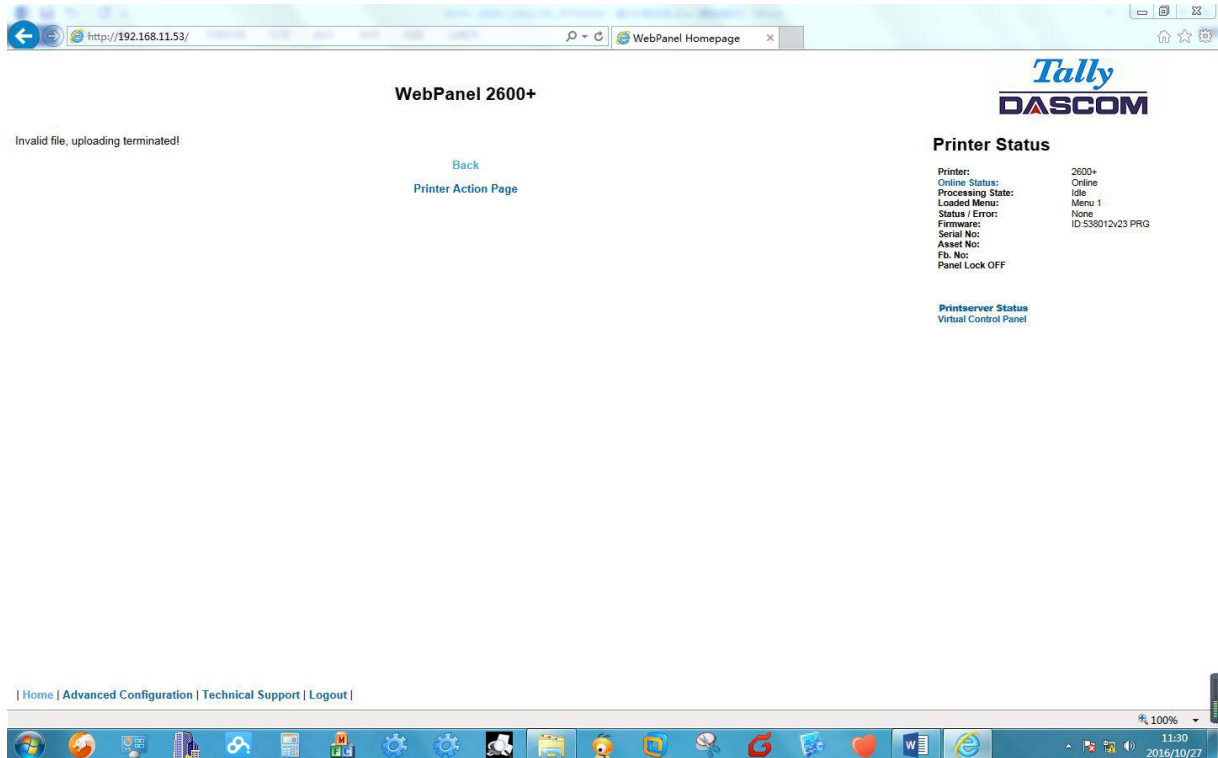

Since the printer will reboot with successful completion of this action, the user will have to reconnect to the printer through the browser.

6.3.12 Report

Selecting the report link will open up a separate browser window and a report of the printer settings will appear. This functionality is the same as pressing the “Print” option on the control panel of the printer.

6.3.13 Reset Printer

This link does a hard reset of the printer, similar to cycling power. There is no user feedback as to success since the printer is rebooting. Since the printer will reboot with successful completion of this action, the user will have to reconnect to the printer through the browser.

6.3.14 Panel Lock On/Off

This link toggles the panel lock feature of the printer. This option affects the physical control panel on the printer as well as the virtual panel in WebPanel. The state of the option is displayed in the printer status page on the right of the display.

6.3.15 Download Firmware

Through this link it is possible to download firmware updates to the printer. When this link is selected, the follow page will appear:

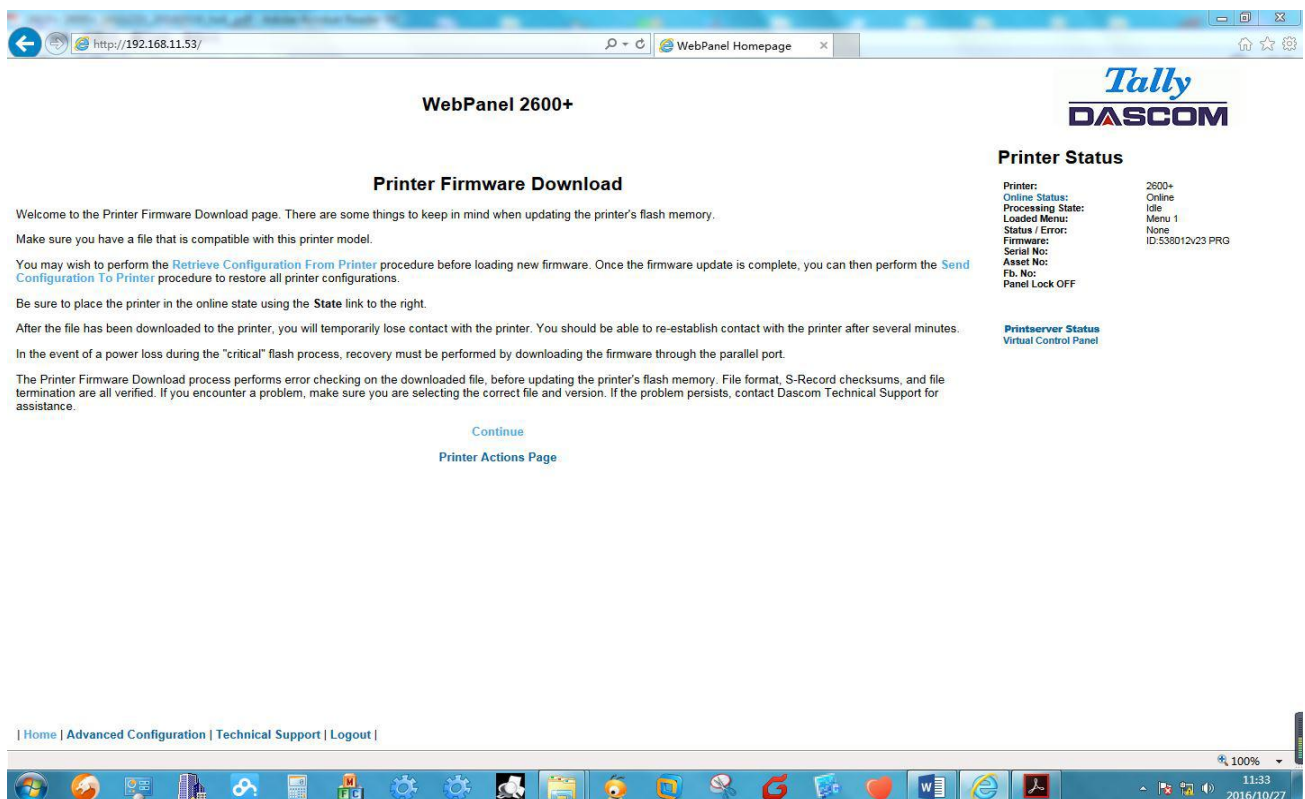

After following the directions on this page, select the “Continue“ link and the following page is displayed:

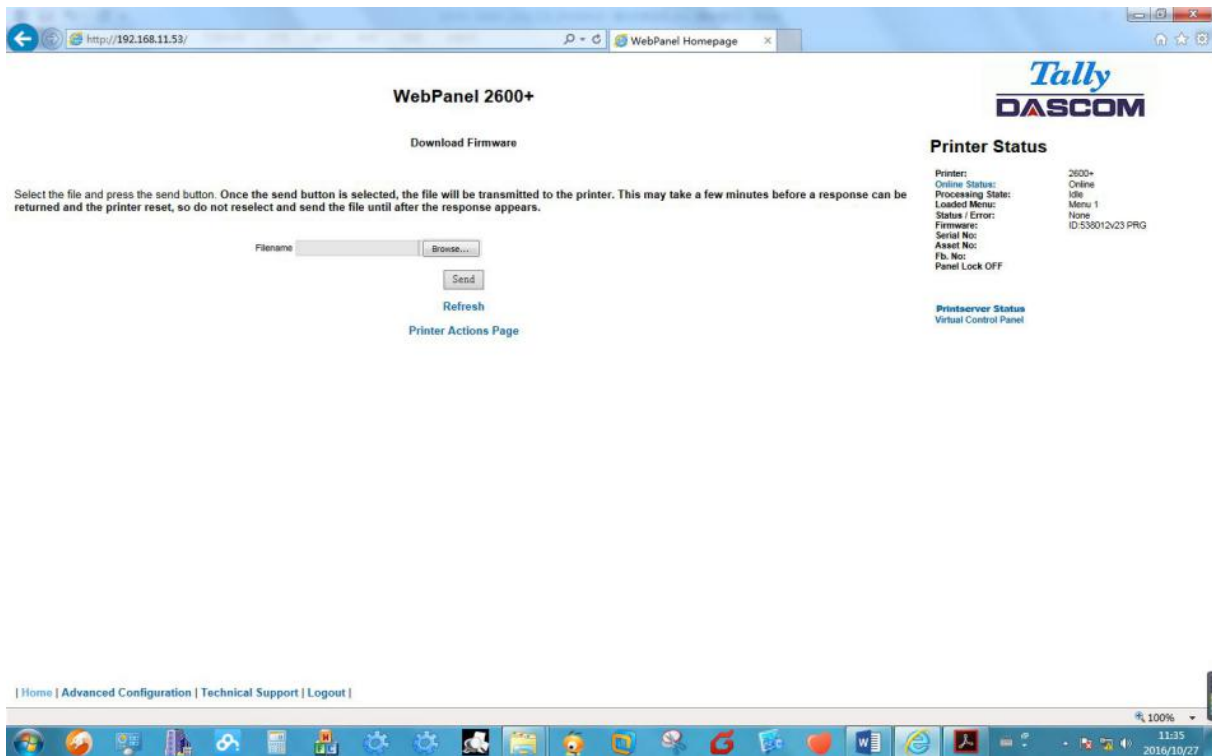

Using the “Browse” button, find the firmware file to download. Once the file is selected, click on the “Send” button. It is important to note the warning on this page. There will be some delay while the file is transmitted so it is important NOT to resend or click on the “Send” button until the process is complete.

If the process is successful, the printer will reboot and the following page will be displayed:

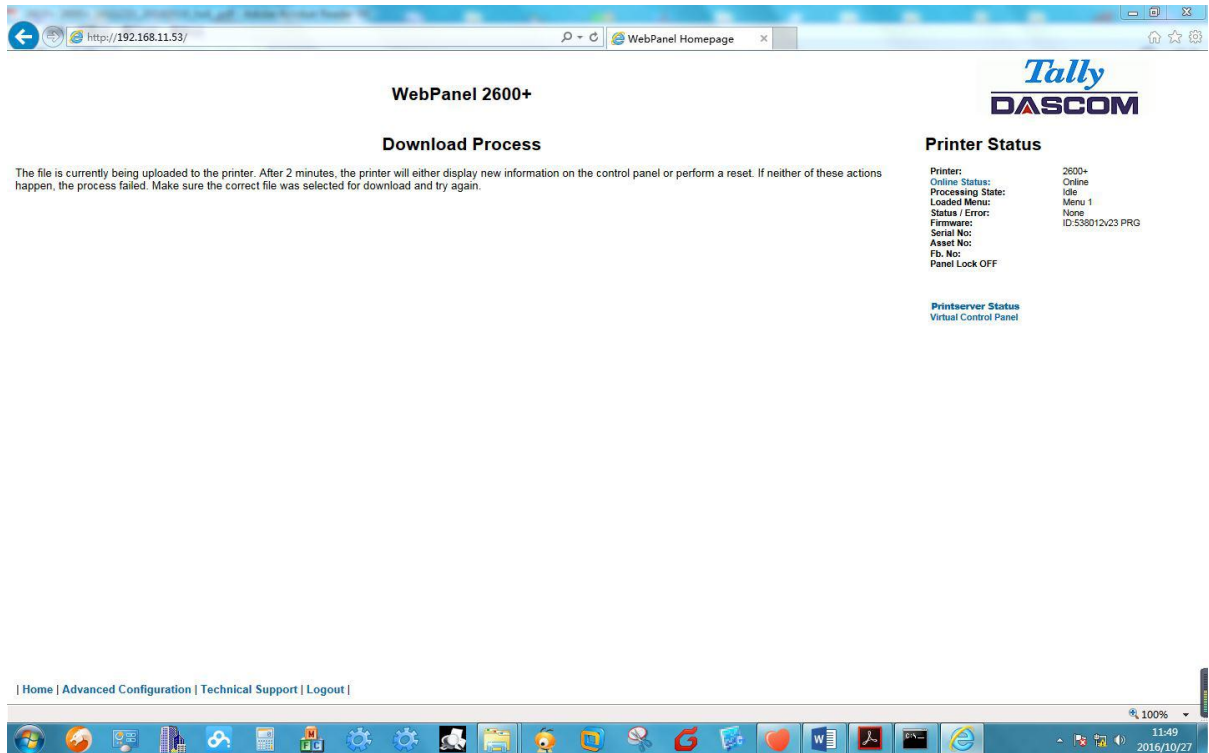

Since the printer will reboot with successful completion of this action, the user will have to reconnect to the printer through the browser.

6.3.16 TallyCom Status

Selecting this link will replace the information in the Printer Status area with networking information on the printer.

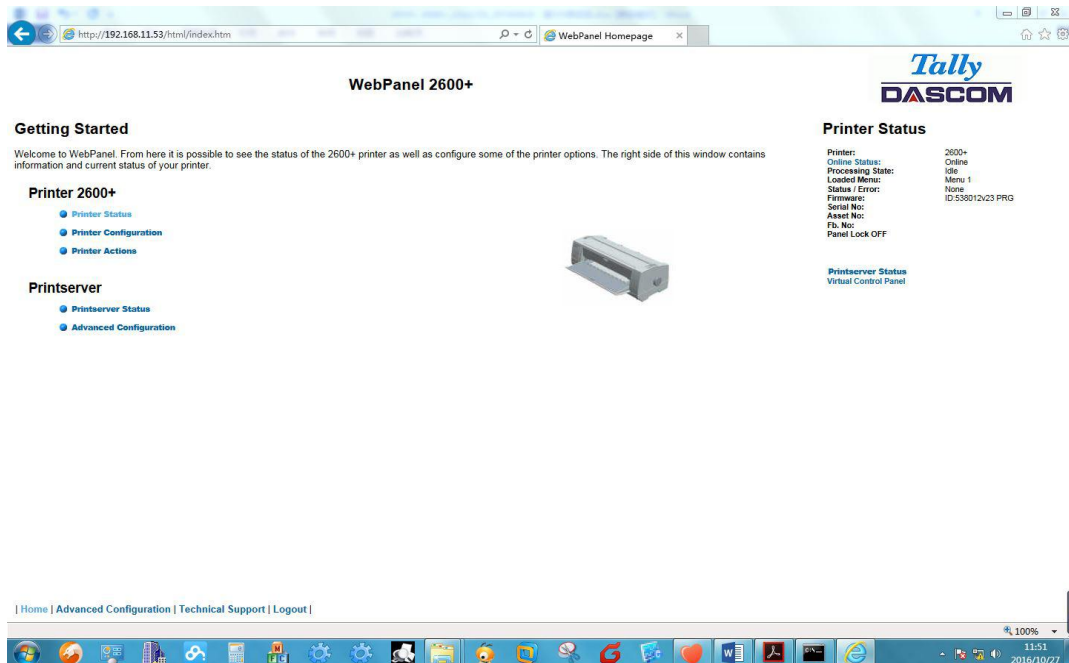

The Name, Contact and Location information is set up from the General link within the Advanced Configuration page.

6.3.17 Advanced Configuration

The Advanced Configuration page allows the user to set up and modify network connectivity information as well as setting up the password, email notification and logical printers. From this page it is also possible to Logout of TallyCom and restart TallyCom. The Administration page looks like this:

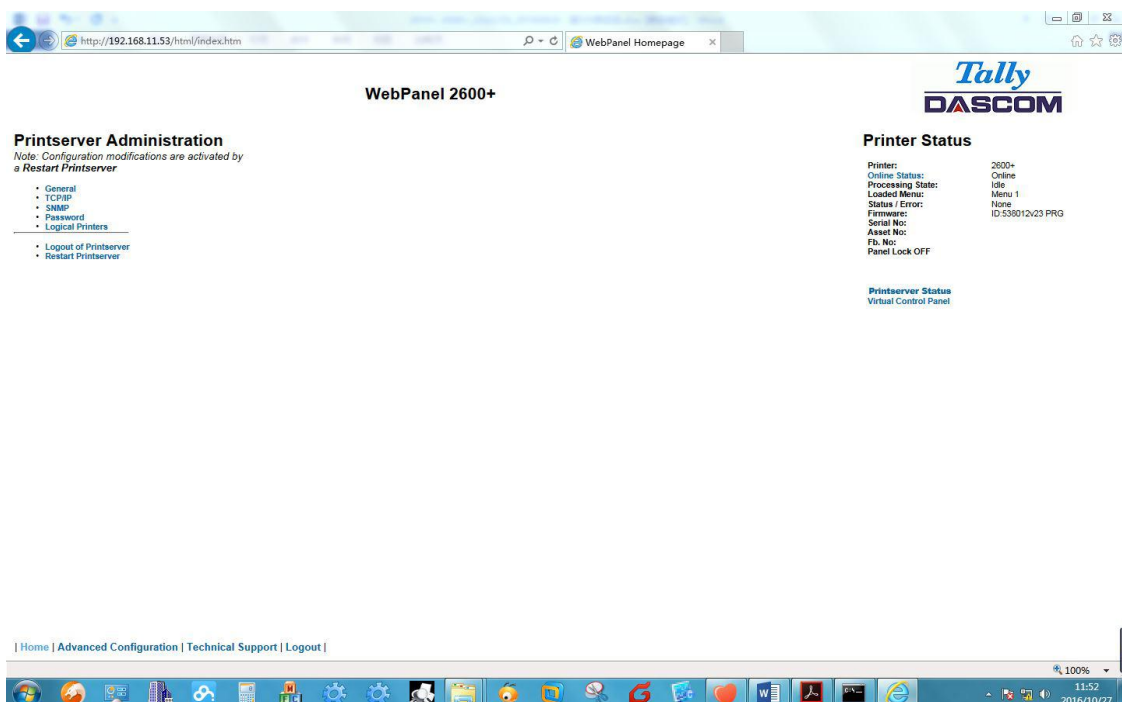

6.3.18 General

The General page sets up the timers and the labels for name, contact and location of the printer.

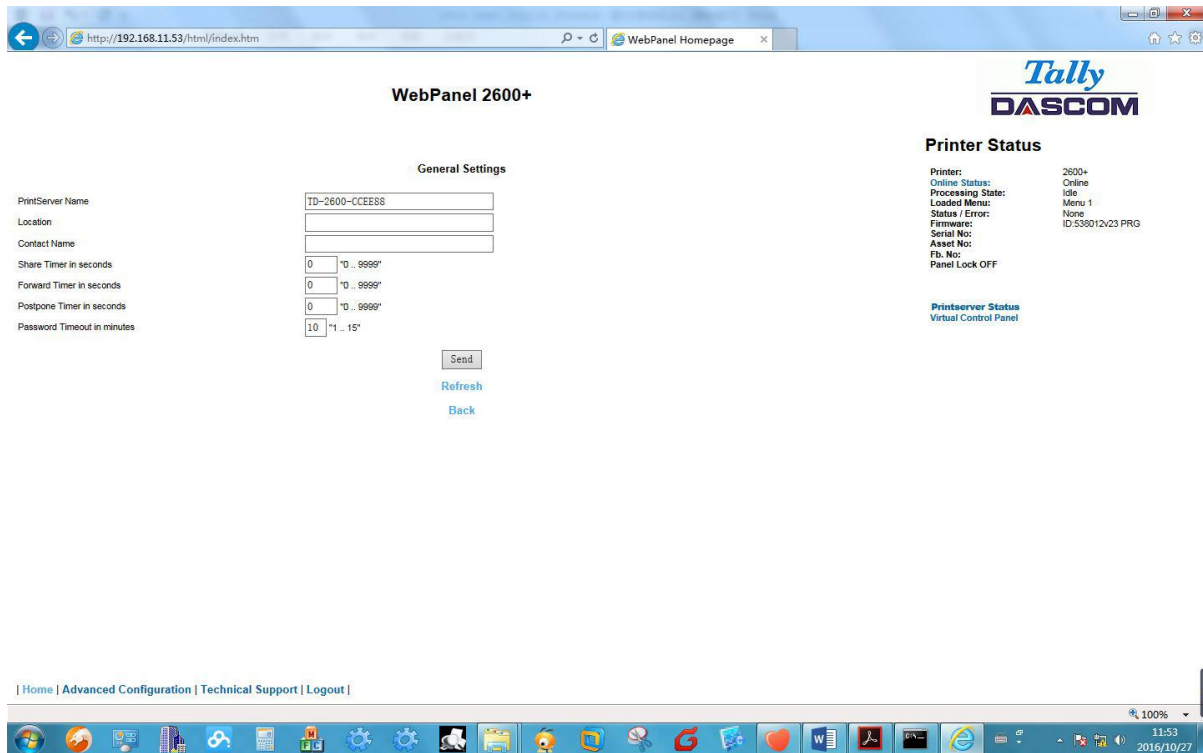

The Print Server Name is given by default and can be changed accordingly. This name is used by Name Server (DNS/DHCP).

6.3.19 TCP/IP

The TCP/IP Page allows the user to modify the existing TCP/IP information for the printer. After changing the particular parameters, it is necessary to restart TallyCom from the Advanced Configuration page. If the IP Address is changed and the Send button selected you will disconnect from the current session and will need to reconnect at the new IP Address.

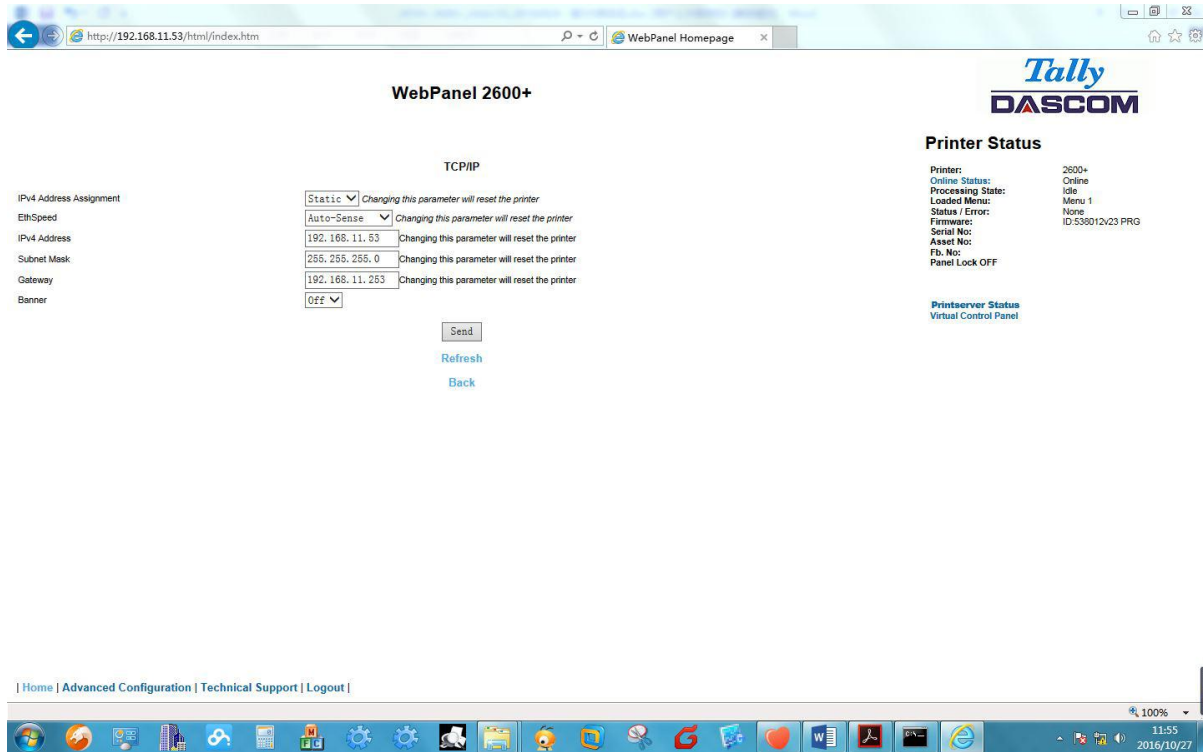

6.3.20 SNMP

The SNMP page allows the user to set the Community Name and the Access. The page looks like this:

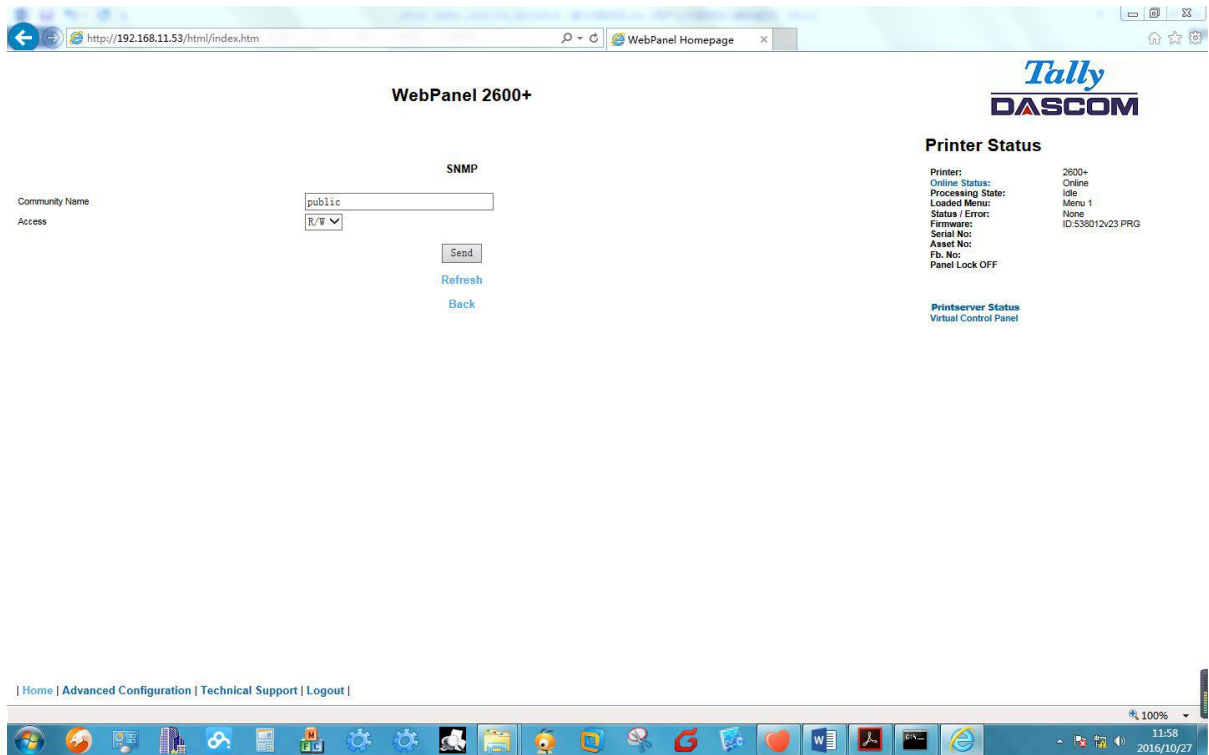

6.3.21 Password

The Password page allows the user to set a password which would limit access to certain configuration and action links in WebPanel. The maximum number of characters for the password is 7. The default password is no password at all (“null”). However, “adm” is also acceptable as the default password to be compatible with the external TallyCom III pocket NICs (Options), which use this as the default password. If this or no password at all (“null”) is set as the password, all of the web pages are accessible by everyone. If any other password is set, the first time a user accesses a password protected page, a window will open asking for verification with user and password information. Once the password has been successfully recognized, all password protected pages will be available. Once the password is recognized, a timer is set, based on the Password Timer value set in the General web page. If there is inactivity in the browser which lasts beyond the timer time, the password will have to be reentered to access the protected pages.

The password page looks like this:

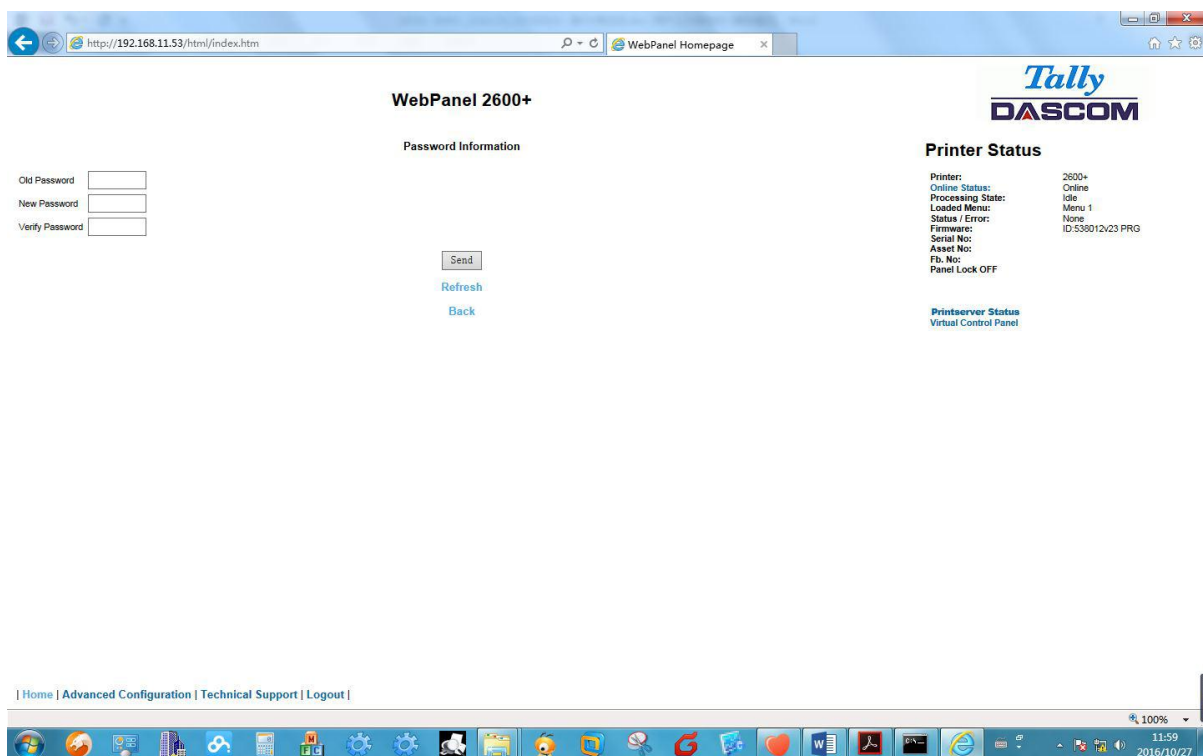

6.3.22 User Name

The default user name is “adm” and cannot be changed.

6.3.23 Resetting Password

In order to reset password the printer needs to be defaulted. See **“Loading Default”**.

6.3.24 Logical Printers

The logical printers_page will add text or commands to the beginning and ending of print jobs. This is done by pre and post strings, defined in each of the logical printers. For entering binary data in these strings, the backslash character is used followed by 2 hexadecimal digits.

Examples of this are \1b for an escape character, \0a for linefeed and \\ for backslash. Selecting the Logical Printers link gives the following page which lists seven possible logical printers plus Raw Port, which is port 9100:

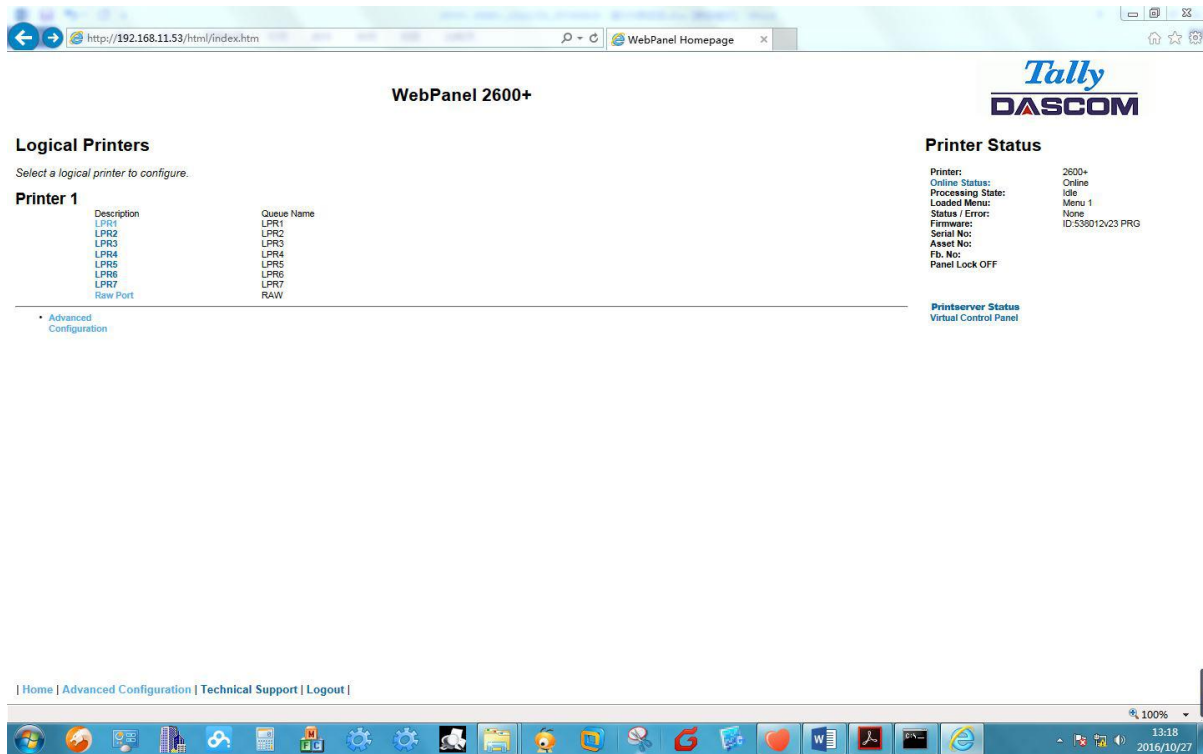

When selecting one of the logical printers under the Description column, the following page is displayed:

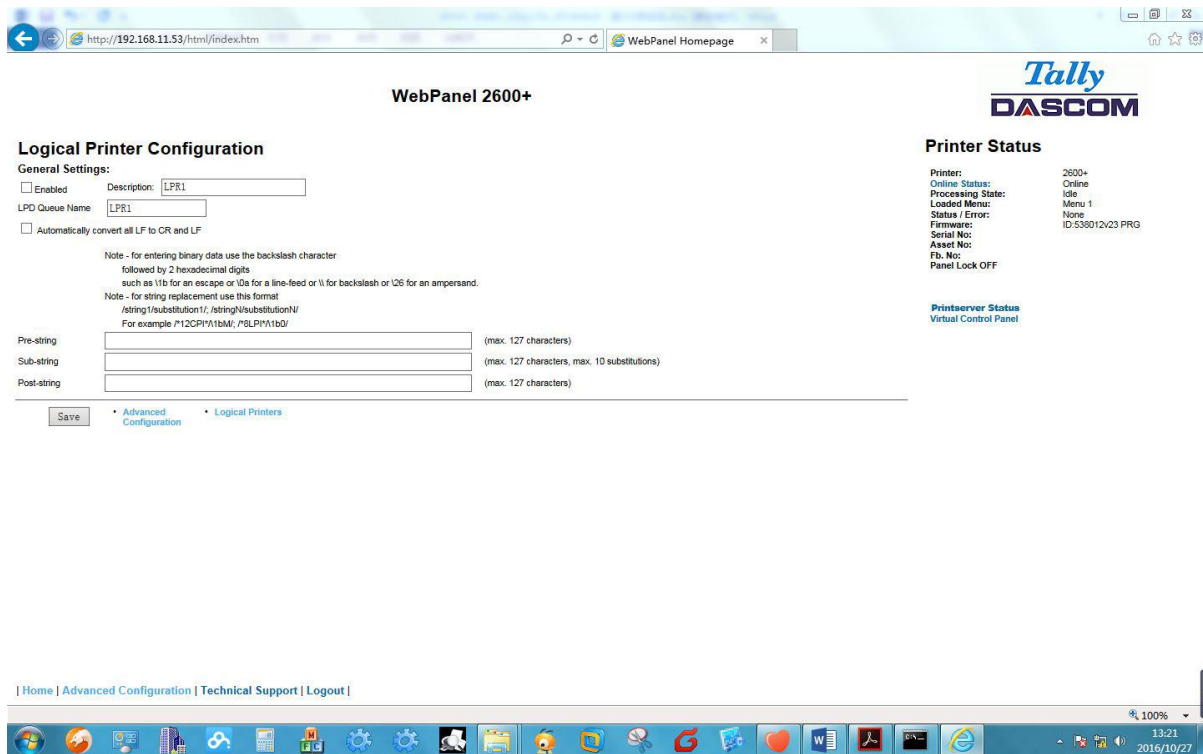

In this example if the Enable checkbox is checked, the pre-string of “Beginning to print job” followed by a CR/LF will print at the beginning of every job sent to this LPR Queue. At the end of the print job, the message “End of job” with a form feed will print. Unchecking the Enable checkbox will not send the pre or post strings. The LPD Queue Name is the name of the print queue that comes from the host. The Description can be changed by the user and does not have to match the LPD Queue Name.

6.3.25 String Replacement Example Plain Text

Original Text / New Text

String Replacement Example Commands `\1B[8419t\1B[4196t/`
 Control codes are entered with a back slash “\”.

In this example the Formlength of A4 (8419”/720) represented by “1B[8419t” is being replaced by the string “1B[4196t” (4196”/720) which results in A5. Multiple strings are separated by a semicolon “;”.

6.3.26 Logout of TallyCom

The Logout link disconnects the browser session from the printer. Clicking on the “Home” link reestablishes the connection.

6.3.27 Restart TallyCom

Selecting this link will reboot the printer and disconnect the current printer connection. It is used to reset certain TCP/IP variables that were set in the General and TCP/IP pages. Once TallyCom has restarted, those new setting will take effect. When this link is selected, the follow page is displayed, giving the user the option to continue or not.

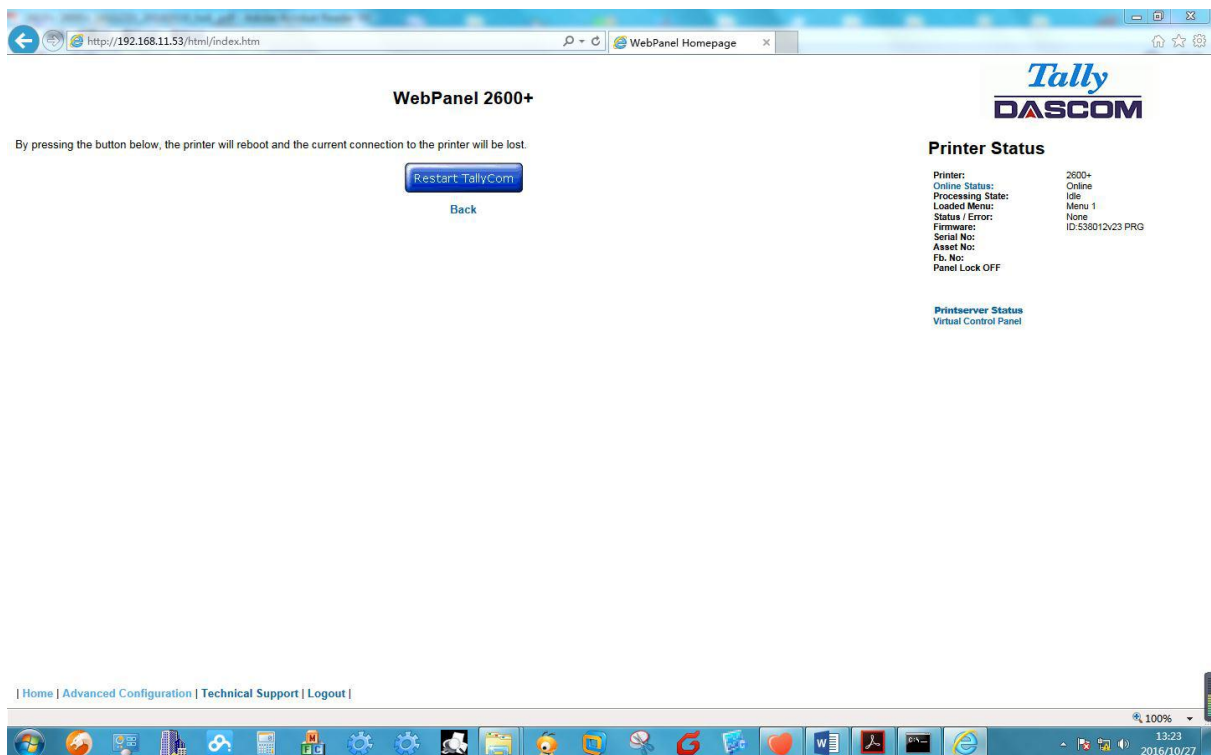

6.3.28 Virtual Control Panel

The Virtual Control Panel link is in the Printer Status area of the web page. This control panel is a visual representation of the actual control panel on the printer. It allows the user to remotely read and set panel information as if they were standing at the control panel. The functionality of the virtual panel is identical to the physical LCD panel.

Before using the virtual panel, it is important to configure the browser to allow popup windows from the printer, otherwise the panel will not display. Once the browser is configured, the page will look similar to this:

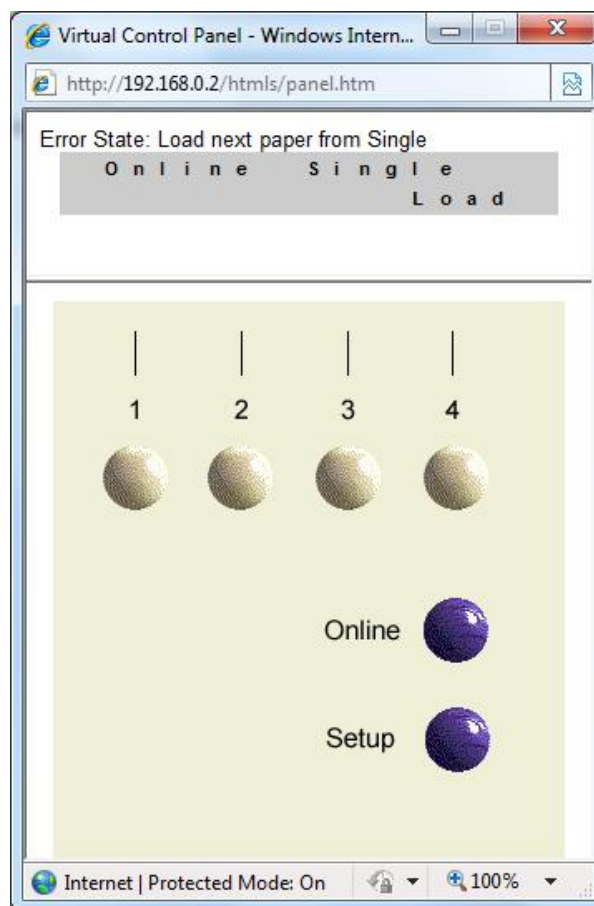

The Virtual Control Panel will be the active window. This window will show the current error state and display the contents of the printer's LCD display. Selecting the buttons on the display will behave the same as if selecting the buttons on the printer itself. The LCD information on the virtual panel refreshes every 15 seconds. The physical panel, virtual panel and Online Status in the Printer Status are all active, so there may be some synchronization delay issues if a user presses a button on the physical printer or the Online Status in the Printer Status area. The Panel Lock feature affects the virtual panel in the same way as the physical panel. The only functional difference between the physical and virtual panel is that in the virtual panel, the LF/FF option will always do a FF.

To close the virtual panel, click on the X in the upper right of the window.



This feature needs the browser to allow pop ups.

7 Addendum

7.1 Character Set

standard character set 1

	0	1	2	3	4	5	6	7	8	9	A	B	C	D	E	F
0	NUL			0	@	P	´	p	NUL		0	@	P	´	p	
1		DC1	!	1	A	Q	a	q		DC1	!	1	A	Q	a	q
2		DC2	"	2	B	R	b	r		DC2	"	2	B	R	b	r
3		DC3	#	3	C	S	c	s		DC3	#	3	C	S	c	s
4		DC4	\$	4	D	T	d	t		DC4	\$	4	D	T	d	t
5			%	5	E	U	e	u			%	5	E	U	e	u
6			&	6	F	V	f	v			&	6	F	V	f	v
7	BEL		'	7	G	W	g	w	BEL		'	7	G	W	g	w
8	BS	CAN	(8	H	X	h	x	BS	CAN	(8	H	X	h	x
9	HT)	9	I	Y	i	y	HT)	9	I	Y	i	y
A	LF		*	:	J	Z	j	z	LF		*	:	J	Z	j	z
B	VT	ESC	+	;	K	[k	{	VT	ESC	+	;	K	[k	{
C	FF	FS	,	<	L	\	l		FF	FS	,	<	L	\	l	
D	CR		-	=	M]	m	}	CR		-	=	M]	m	}
E	SO		.	>	N	^	n	~	SO		.	>	N	^	n	~
F	SI		/	?	O	_	o		SI		/	?	O	_	o	DEL

standard character set 2

	0	1	2	3	4	5	6	7	8	9	A	B	C	D	E	F
0	NUL			0	@	P	´	p	à	\$		0	@	P	´	p
1		DC1	!	1	A	Q	a	q	è	β	!	1	A	Q	a	q
2		DC2	"	2	B	R	b	r	ù	Æ	"	2	B	R	b	r
3		DC3	#	3	C	S	c	s	ò	œ	#	3	C	S	c	s
4		DC4	\$	4	D	T	d	t	ì	ø	\$	4	D	T	d	t
5			%	5	E	U	e	u	°	ø	%	5	E	U	e	u
6			&	6	F	V	f	v	£	¨	&	6	F	V	f	v
7	BEL		'	7	G	W	g	w	ı	Ä	'	7	G	W	g	w
8	BS	CAN	(8	H	X	h	x	ç	Ö	(8	H	X	h	x
9	HT)	9	I	Y	i	y	ñ	Û)	9	I	Y	i	y
A	LF		*	:	J	Z	j	z	ñ	ä	*	:	J	Z	j	z
B	VT	ESC	+	;	K	[k	{	ı	ö	+	;	K	[k	{
C	FF	FS	,	<	L	\	l		È	ü	,	<	L	\	l	
D	CR		-	=	M]	m	}	Ä	É	-	=	M]	m	}
E	SO		.	>	N	^	n	~	á	é	.	>	N	^	n	~
F	SI		/	?	O	_	o		Ç	¥	/	?	O	_	o	DEL

IBM character set 1

	0	1	2	3	4	5	6	7	8	9	A	B	C	D	E	F
0	NUL			0	@	P	´	p	NUL		á	⋮	L	⊥	α	≡
1		DC1	!	1	A	Q	a	q		DC1	í	⋮	⊥	⊥	β	±
2		DC2	"	2	B	R	b	r		DC2	ó	■	⊥	⊥	Γ	≥
3		DC3	#	3	C	S	c	s		DC3	ú		⊥	L	π	≤
4		DC4	\$	4	D	T	d	t		DC4	ñ	⊥	⊥	L	Σ	ρ
5			%	5	E	U	e	u			Ñ	⊥	+	Γ	σ	J
6			&	6	F	V	f	v			ª	⊥	⊥	Γ	μ	÷
7	BEL		'	7	G	W	g	w	BEL		º	⊥	⊥	+	τ	≈
8	BS	CAN	(8	H	X	h	x	BS	CAN	¿	⊥	L	+	Φ	°
9	HT)	9	I	Y	i	y	HT		⊥	⊥	⊥	⊥	θ	•
A	LF		*	:	J	Z	j	z	LF		⊥		⊥	Γ	Ω	.
B	VT	ESC	+	;	K	[k	{	VT	ESC	½	⊥	⊥	■	δ	√
C	FF	FS	,	<	L	\	l		FF	FS	¼	⊥	⊥	⊥	∞	ª
D	CR		-	=	M]	m	}	CR		¡	⊥	⊥	⊥	∅	²
E	SO		.	>	N	^	n	~	SO		«	⊥	+	⊥	ε	■
F	SI		/	?	O	_	o		SI		»	⊥	⊥	⊥	∩	

IBM character set 2

	0	1	2	3	4	5	6	7	8	9	A	B	C	D	E	F
0	NUL			0	@	P	´	p	Ç	É	á	⋮	L	⊥	α	≡
1		DC1	!	1	A	Q	a	q	ü	æ	í	⋮	⊥	⊥	β	±
2		DC2	"	2	B	R	b	r	é	Æ	ó	■	⊥	⊥	Γ	≥
3	♥	DC3	#	3	C	S	c	s	â	ô	ú		⊥	L	π	≤
4	♦	DC4	\$	4	D	T	d	t	ä	ö	ñ	⊥	⊥	L	Σ	ρ
5	♣		%	5	E	U	e	u	à	ò	Ñ	⊥	+	Γ	σ	J
6	♠		&	6	F	V	f	v	á	û	ª	⊥	⊥	Γ	μ	÷
7	BEL		'	7	G	W	g	w	Ç	ù	º	⊥	⊥	+	τ	≈
8	BS	CAN	(8	H	X	h	x	ê	ÿ	¿	⊥	L	+	Φ	°
9	HT)	9	I	Y	i	y	ë	Ö	⊥	⊥	⊥	⊥	θ	•
A	LF		*	:	J	Z	j	z	è	Û	⊥		⊥	Γ	Ω	.
B	VT	ESC	+	;	K	[k	{	ï	Ø	½	⊥	⊥	■	δ	√
C	FF	FS	,	<	L	\	l		î	£	¼	⊥	⊥	⊥	∞	ª
D	CR		-	=	M]	m	}	ì	¥	¡	⊥	⊥	⊥	∅	²
E	SO		.	>	N	^	n	~	Ä	℞	«	⊥	+	⊥	ε	■
F	SI		/	?	O	_	o		Å	f	»	⊥	⊥	⊥	∩	

OCR-A character set 1

	0	1	2	3	4	5	6	7	8	9	A	B	C	D	E	F
0	NUL			0	H	P	'	p	NUL							
1		DC1	4	1	A	Q	a	q		DC1						
2		DC2	"	2	B	R	b	r		DC2						
3		DC3	¶	3	C	S	c	s		DC3						
4		DC4	≠	4	D	T	d	t		DC4						
5			%	5	E	U	e	u								
6			&	6	F	V	f	v								
7	BEL		'	7	G	W	g	w	BEL							
8	BS	CAN	{	8	H	X	h	x	BS	CAN						
9	HT		}	9	I	Y	i	y	HT							
A	LF		*	:	J	Z	j	z	LF							
B	VT	ESC	+	;	K	[k	(VT	ESC						
C	FF	FS	,	█	L	\	l		FF	FS						
D	CR		-	=	M]	m)	CR							
E	SO		.	█	N	^	n	~	SO							
F	SI		/	?	0	_	o	.	SI							

OCR-A character set 2

	0	1	2	3	4	5	6	7	8	9	A	B	C	D	E	F
0	∅	▶		0	H	P	'	p								
1	☉	◀	4	1	A	Q	a	q								
2	☼	↑	"	2	B	R	b	r								
3	♥	!!	¶	3	C	S	c	s								
4	♦	¶	≠	4	D	T	d	t								
5	♣	§	%	5	E	U	e	u								
6	♠	_	&	6	F	V	f	v								
7	•	↑	'	7	G	W	g	w								
8	☐	↑	{	8	H	X	h	x								
9	◦	↓	}	9	I	Y	i	y								
A	■	→	*	:	J	Z	j	z								
B	♂	←	+	;	K	[k	(
C	♀	L	,	█	L	\	l									
D	♪	↔	-	=	M]	m)								
E	♫	▲	.	█	N	^	n	~								
F	♫	▼	/	?	0	_	o	.								

OCR-B character set 1

	0	1	2	3	4	5	6	7	8	9	A	B	C	D	E	F
0	NUL			0	@	P	'	p	NUL							
1		DC1	!	1	A	Q	a	q		DC1						
2		DC2	"	2	B	R	b	r		DC2						
3		DC3	#	3	C	S	c	s		DC3						
4		DC4	\$	4	D	T	d	t		DC4						
5			%	5	E	U	e	u								
6			&	6	F	V	f	v								
7	BEL		'	7	G	W	g	w	BEL							
8	BS	CAN	(8	H	X	h	x	BS	CAN						
9	HT)	9	I	Y	i	y	HT							
A	LF		*	:	J	Z	j	z	LF							
B	VT	ESC	+	;	K	[k	{	VT	ESC						
C	FF	FS	,	<	L	\	l		FF	FS						
D	CR		-	=	M]	m	}	CR							
E	SO		.	>	N	^	n	~	SO							
F	SI		/	?	O	_	o	.	SI							

OCR-B character set 2

	0	1	2	3	4	5	6	7	8	9	A	B	C	D	E	F
0	∅	▶		0	@	P	'	p								
1	☺	◀	!	1	A	Q	a	q								
2	☹	↑	"	2	B	R	b	r								
3	♥	!!	#	3	C	S	c	s								
4	♦	¶	\$	4	D	T	d	t								
5	♣	§	%	5	E	U	e	u								
6	♠	_	&	6	F	V	f	v								
7	•	↓	'	7	G	W	g	w								
8	☐	↑	(8	H	X	h	x								
9	◦	↓)	9	I	Y	i	y								
A	■	→	*	:	J	Z	j	z								
B	♂	←	+	;	K	[k	{								
C	♀	L	,	<	L	\	l									
D	♪	↔	-	=	M]	m	}								
E	♫	▲	.	>	N	^	n	~								
F	☼	▼	/	?	O	_	o	.								

International Character Set Commands

Country	Basic Command
USA	<ESC>"R"CHR \$ (0)
FRANCE	<ESC>"R"CHR \$ (1)
GERMANY	<ESC>"R"CHR \$ (2)
UK	<ESC>"R"CHR \$ (3)
DENMARK 1	<ESC>"R"CHR \$ (4)
SWEDEN	<ESC>"R"CHR \$ (5)
ITALY	<ESC>"R"CHR \$ (6)
SPAIN 1	<ESC>"R"CHR \$ (7)
JAPAN	<ESC>"R"CHR \$ (8)
NORWAY	<ESC>"R"CHR \$ (9)
DENMARK 2	<ESC>"R"CHR \$ (10)
SPAIN 2	<ESC>"R"CHR \$ (11)
LATINAMERICA	<ESC>"R"CHR \$ (12)
DENMARK/NORWAY	<ESC>"R"CHR \$ (13)
CHINA	<ESC>"R"CHR \$ (16)

International character sets:

Character Set	Character Code (Hex)											
	23	24	40	5B	5C	5D	5E	60	7B	7C	7D	7E
0: U. S. A.	#	\$	@	[\]	^	‘	{		}	~
1: FRANCE	#	\$	à	°	ç	§	^	‘	é	ù	è	-
2: GERMANY	#	\$	§	Ä	Ö	Ü	^	‘	ä	ö	ü	ß
3: U. K.	£	\$	@	[\]	^	‘	{		}	~
4: DENMARK 1	#	\$	@	Æ	Ø	Å	^	‘	æ	Ø	å	~
5: SWEDEN	#	□	É	Ä	Ö	Å	Ü	é	ä	Ö	å	ü
6: ITALY	#	\$	@	°	\	é	^	‘	ù	à	ò	è
7: SPAIN 1	Pt	\$	@	ı	Ñ	¿	^	‘	-	ñ	}	~
8: JAPAN	#	\$	@	[¥]	^	‘	{		}	~
9: NORWAY	#	□	É	Æ	Ø	Å	Ü	é	æ	Ø	å	ü
10: DENMARK 2	#	\$	É	Æ	Ø	Å	Ü	é	æ	Ø	å	ü
11: SPAIN 2	#	\$	á	ı	Ñ	¿	é	‘	ı	ñ	ó	ú
12: LATIN AMERICA	#	\$	á	ı	Ñ	¿	é	‘	ı	ñ	ó	ú
13: DENMARK/NORWAY	#	\$	@	[\]	^	‘	{		}	~
14: CHINA	#	¥	@	[\]	^	‘	{		}	~

7.2 Control Codes Summary

The following table shows sequences marked by a ✓ if they are available in the various emulations. The MTPL sequences can be used within all emulation modes. The corresponding sequences are marked by a *.



If you want to learn more about control codes, we recommend to download the Programmer's Application Manual from our internet support pages.

MTPL	IBM XL24	IBM AGM	Epson LQ-2550	Epson LQ-2170	Code	Function
✓	✓		✓	✓	<BEL>	Signal tone
✓	✓	✓	✓	✓	<BS>	Control character BS (Backspace)
			✓	✓	<CAN>	Deleting a data line
✓	✓	✓	✓	✓	<CR>	Control character CR (Carriage return)
✓					<CSI>	Start character for MTPL sequences, corr. ESC [
			✓	✓	<DC1>	Selecting the printer
			✓	✓	<DC2>	Condensed printing OFF (set by <SI> or <ESC><SI>)
			✓	✓	<DC3>	Deselecting the printer
			✓	✓	<DC4>	Double-wide printing OFF (set by <SO> or <ESC><SO>)
✓	✓	*	✓	✓		Delete line. Epson: Delete last character
✓	✓	✓	✓	✓	<ESC>	Start character for programming sequence
	✓	✓	✓	✓	<ESC>!<n>	Print mode selection
		✓	✓	✓	<ESC>#	Bit 8 = unchanged
			✓	✓	<ESC>\$<n1><n2>	Perform absolute horizontal step
			✓	✓	<ESC>%<0><0>	Select ROM character generator
			✓	✓	<ESC>%<1><0>	Select download generator
✓	*	*	*	*	<ESC>%1<n1><n2>	Graphics print with 180 dpi/HQ
✓	*	*	*	*	<ESC>%2<n1><n2>	Graphics print with 360 dpi/HQ
✓	*	*	*	*	<ESC>%3<n1> <n2>	Graphics print with 60 dpi
✓	*	*	*	*	<ESC>%4<n1> <n2>	Graphics print with 120 dpi
✓	*	*	*	*	<ESC>%5<n1> <n2>	Graphics print with 80 dpi
✓	*	*	*	*	<ESC>%7<n1> <n2>	Graphics print with 240 dpi
✓	*	*	*	*	<ESC>%8<n1> <n2>	Graphics print with 72 dpi
✓	*	*	*	*	<ESC>%9<n1><n2>	Graphics print with 90 dpi
			✓	✓	<ESC>&<s><x><y>..	Define download character
✓	*	*	*	*	<ESC>(&	Character set ISO 8859-2
✓	*	*	*	*	<ESC>(*	Character set ISO 8859-5
✓	*	*	*	*	<ESC>(+	Character set ISO 8859-1 SAP

MTPL	IBM XL24	IBM AGM	Epson LQ-2550	Epson LQ-2170	Code	Function
√	*	*	*	*	<ESC>.	Character set ISO 8859-9
√	*	*	*	*	<ESC>/	Character set ISO 8859-15
√	*	*	*	*	<ESC>(<	Character set Cro ASCII
				√	<ESC>(c	Defining the page format
				√	<ESC>(v	Relative vertical printing position
				√	<ESC>(t	Assigning a character table
√	*	*	*	*	<ESC>(m	Character set BRASCII
√	*	*	*	*	<ESC>(n	Character set Abicomp
√	*	*	*	*	<ESC>(p	Windows character set 1250 (Latin2)
√	*	*	*	*	<ESC>(q	Windows character set 1251 (Cyrillic)
√	*	*	*	*	<ESC>(r	Windows character set 1252 (Latin1)
√	*	*	*	*	<ESC>(t	Windows character set 1254 (Turkish)
√	*	*	*	*	<ESC>(`	Character set Norwegian
				√	<ESC>(^<n1><n2><d1><dn>	Print data as characters
√	*	*	*	*	<ESC>(A	Character set UK-ASCII
√	*	*	*	*	<ESC>(B	Character set US-ASCII
				√	<ESC>(B<n1>-<n8>	Barcode Setup and print
				√	<ESC>(C	Defining the page length
√	*	*	*	*	<ESC>(MI>F	Assign character set G0
				√	<ESC>(G	Selecting graphics mode
√	*	*	*	*	<ESC>(H	Character set Swedish-Finnish
√	*	*	*	*	<ESC>(K	Character set German
√	*	*	*	*	<ESC>(L	Character set Portuguese
√	*	*	*	*	<ESC>(R	Character set French
				√	<ESC>(U	Setting positioning units in n/3600 inch
				√	<ESC>(V	Absolute vertical printing position
√	*	*	*	*	<ESC>(Y	Character set Italian
√	*	*	*	*	<ESC>(Z	Character set Spanish
√	*	*	*	*	<ESC>)MI>F	Assign character set G1
		√	√	√	<ESC>*<0><n1> <n2>	Set graphics print to 60 dpi
		√	√	√	<ESC>*<1><n1> <n2>	Set graphics print to 120 dpi
		√	√	√	<ESC>*<2><n1> <n2>	Set graphics print to 120 dpi
		√	√	√	<ESC>*<3><n1> <n2>	Set graphics print to 240 dpi
		√	√	√	<ESC>*<32><n1> <n2>	Set graphics print to 60 dpi
		√	√	√	<ESC>*<33><n1> <n2>	Set graphics print to 120 dpi
		√	√	√	<ESC>*<38><n1> <n2>	Set graphics print to 90 dpi
		√	√	√	<ESC>*<39><n1> <n2>	Set graphics print to 180 dpi

MTPL	IBM XL24	IBM AGM	Epson LQ-2550	Epson LQ-2170	Code	Function
		√	√	√	<ESC>*<4><n1> <n2>	Set graphics print to 80 dpi
		√	√	√	<ESC>*<40><n1> <n2>	Set graphics print to 360 dpi
√	*	*	*	*	<ESC>*MI>F	Assign character set G2
	√	√	√		<ESC>-<n>	Underlining ON/OFF
			√		<ESC>/<m>	Select vertical tab channels
				√	<ESC>.	Printing raster graphics
	√	√			<ESC>:	Condensed printing 12 cpi ON
			√	√	<ESC>:<0><n><m>	Copy ROM character set
			√	√	<ESC><<	Unidirectional printing for 1 line
			√	√	<ESC>=>	Set bit 8 = 0
	√	√			<ESC>=<C1><C2>...	Load font/character set
			√	√	<ESC>>>	Set bit 8 = 1
			√	√	<ESC>?<s><n>	Reload a graphics mode
			√	√	<ESC>@	Initialize printer
√	*	*	*	*	<ESC>[MTPL start character for programming sequence
√	*	*	*	*	<ESC>[y	Right justification and centering OFF
√	*	*	*	*	<ESC>[=z	Bold ON
√	*	*	*	*	<ESC>[>z	Bold OFF
√	*	*	*	*	<ESC>[?1~	MTPL command set
√	*	*	*	*	<ESC>[?10~	Barcode interpretation OFF
√	*	*	*	*	<ESC>[?11~	Start barcode interpretation
√	*	*	*	*	<ESC>[?4~	MTPL + IBM Proprinter-24 command set
√	*	*	*	*	<ESC>[?50h	Selecting character sets with 256 characters
√	*	*	*	*	<ESC>[?50l	Selecting character sets with 94 characters
√	*		*	*	<ESC>[?51h	Proportional fonts automatic NLQ and LQ
√	*		*	*	<ESC>[?51l	Proportional fonts in draft mode possible
√	*	*	*	*	<ESC>[?52h	Font selection (ESC[10...19m]) possible only for NLQ and LQ
√	*	*	*	*	<ESC>[?52l	Font selection (ESC[10...19m]) Draft
√	*	*	*	*	<ESC>[?53h	Extended character set
√	*	*	*	*	<ESC>[?53l	Standard character set
√	*	*	*	*	<ESC>[?6~	MTPL + EPSON LQ-2550 command set
√	*	*	*	*	<ESC>[?8~	MTPL + EPSON LQ-2170 command set
√	*	*	*	*	<ESC>[?7h	Line overrun = CR + LF

MTPL	IBM XL24	IBM AGM	Epson LQ-2550	Epson LQ-2170	Code	Function
√	*	*	*	*	<ESC>[?7I	Line overrun = Truncating data outside of the printing area
√	*	*	*	*	<ESC>[?<n>~	Change emulation
	√	√			<ESC>[@<n1> <n2>...	Set double height
	√	√			<ESC>[\<n1> <n2>...	Change vertical base units
√	*	*	*	*	<ESC>[0;n{	Select single sheet operation
√	*	*	*	*	<ESC>[0;0r	Clear top and bottom margin
√	*	*	*	*	<ESC>[0;0s	Clear left and right margin
√	*	*	*	*	<ESC>[0g	Clear horizontal tab at the current print head position
√	*	*	*	*	<ESC>[0m	Clear all selected fonts
√	*	*	*	*	<ESC>[0m	Reset color (reserved)
√	*	*	*	*	<ESC>[0 SP I	Measuring unit decipoint
√	*	*	*	*	<ESC>[0 SP K	Set horizontal pitch to 10 cpi
√	*	*	*	*	<ESC>[0 SP L	Set vertical spacing to 6 lpi
√	*	*	*	*	<ESC>[0 SP X	LQ print quality
√	*	*	*	*	<ESC>[0w	Set 5 cpi
√	*	*	*	*	<ESC>[0y	Selecting Draft printing quality
√	*	*	*	*	<ESC>[0z	Superscript ON
√	*	*	*	*	<ESC>[10m	Font 0 Default: Draft
√	*	*	*	*	<ESC>[10y	Right and center adjustment OFF
√	*	*	*	*	<ESC>[10z	Microscript ON
√	*	*	*	*	<ESC>[11e	Set PUM (absolute measuring unit) to OFF
√	*	*	*	*	<ESC>[11h	Set PUM (absolute measuring unit) to ON
√	*	*	*	*	<ESC>[11m	Font 1 Default: Courier NLQ
√	*	*	*	*	<ESC>[11w	Set 20 cpi
√	*	*	*	*	<ESC>[11y	Select print quality HS-Draft
√	*	*	*	*	<ESC>[12m	Font 2 Default: Courier LQ
√	*	*	*	*	<ESC>[12 SP K	Set horizontal pitch to 12 cpi
√	*	*	*	*	<ESC>[12w	Set horizontal pitch to 10 cpi
√	*	*	*	*	<ESC>[12y	Select print quality LQ
√	*	*	*	*	<ESC>[12z	Double height ON (top portion)
√	*	*	*	*	<ESC>[13m	Font 3 Default: Sans Serif NLQ
√	*	*	*	*	<ESC>[13y	Select print quality LQ
√	*	*	*	*	<ESC>[13z	Double height ON (lower portion)
√	*	*	*	*	<ESC>[14m	Font 4 Default: Sans Serif LQ
√	*	*	*	*	<ESC>[15m	Font 5 Default: Roman LQ
√	*	*	*	*	<ESC>[15 SP K	Set horizontal pitch to 15 cpi

MTPL	IBM XL24	IBM AGM	Epson LQ-2550	Epson LQ-2170	Code	Function
√	*	*	*	*	<ESC>[16m	Font 6 Default: Script LQ
√	*	*	*	*	<ESC>[17m	Font 7 Default: Prestige LQ
√	*	*	*	*	<ESC>[18m	Font 8 Default: OCR-B LQ
√	*	*	*	*	<ESC>[19m	Font 9 Default: OCR-A LQ
√	*	*	*	*	<ESC>[1 g	Clear vertical tab at current position
√	*	*	*	*	<ESC> [1 SP k	Printout in Royal Mail customer barcode
√	*	*	*	*	<ESC>[1 SP L	Set vertical spacing to 4 lpi
√	*	*	*	*	<ESC>[1 SP p	Initiate US Postnet Barcode
√	*	*	*	*	<ESC>[1 SP X	Print quality NLQ
√	*	*	*	*	<ESC>[1w	Set 6 cpi
√	*	*	*	*	<ESC>[1y	Print quality NLQ
√	*	*	*	*	<ESC>[1z	Subscript ON
√	*	*	*	*	<ESC>[21{	ASF-1: Select feeder front
√	*	*	*	*	<ESC>[22{	ASF-2: Select feeder rear
√	*	*	*	*	<ESC>[21m	Double underlining
√	*	*	*	*	<ESC>[23m	Italics OFF
√	*	*	*	*	<ESC>[24m	Underline OFF
√	*	*	*	*	<ESC>[26m	Proportional font ON
√	*	*	*	*	<ESC>[2g	Clear all horizontal tabs in the current line
√	*	*	*	*	<ESC>[2J	Print page
√	*	*	*	*	<ESC>[2 SP l	Measuring unit decipoint
√	*	*	*	*	<ESC> [2 SP k	Printout in Kix barcode
√	*	*	*	*	<ESC>[2 SP L	Set vertical spacing to 3 lpi
√	*	*	*	*	<ESC>[2 SP X	Print quality Draft
√	*	*	*	*	<ESC>[2w	Set 7.5 cpi
√	*	*	*	*	<ESC>[2y	Proportional font ON
√	*	*	*	*	<ESC>[2z	Double height OFF
√	*	*	*	*	<ESC>[2z	Superscript, subscript and microscript OFF
√	*	*	*	*	<ESC>[30m	Black
√	*	*	*	*	<ESC>[<n>m	Color; n = 31...36
√	*	*	*	*	<ESC>[3g	Clear all horizontal tabs
√	*	*	*	*	<ESC>[3m	Italics ON
√	*	*	*	*	<ESC>[3 SP L	Set vertical spacing to 12 lpi
√	*	*	*	*	<ESC>[3w	Set 8.6 cpi
√	*	*	*	*	<ESC>[3z	Line density 6 lpi (= line spacing 1/6 inch)
√	*	*	*	*	<ESC>[4g	Clear all vertical tabs

MTPL	IBM XL24	IBM AGM	Epson LQ-2550	Epson LQ-2170	Code	Function
√	*	*	*	*	<ESC>[4m	Underline ON
√	*	*	*	*	<ESC>[4 SP L	Set vertical spacing to 8 lpi
√	*	*	*	*	<ESC>[4w	Set 10 cpi
√	*	*	*	*	<ESC>[4y	Selecting NLQ printing quality at 10 cpi
√	*	*	*	*	<ESC>[4z	Line density 8 lpi (= line spacing 1/8 inch)
√	*	*	*	*	<ESC>[5{	Select fanfold paper mode tractor 1
√	*	*	*	*	<ESC>[6{	Select fanfold paper mode tractor 2
√	*	*	*	*	<ESC>[50m	Proportional font OFF
√	*	*	*	*	<ESC>[50{	Page at print position
√	*	*	*	*	<ESC>[51{	Page at tear off position (perforation)
√	*	*	*	*	<ESC>[52{	Page at view position
√	*	*	*	*	<ESC>[53m	Overlining ON
√	*	*	*	*	<ESC>[55m	Overlining OFF
√	*	*	*	*	<ESC>[5n	Request status report
√	*	*	*	*	<ESC>[5w	Set 12 cpi
√	*	*	*	*	<ESC>[5y	NLQ with 12 cpi
√	*	*	*	*	<ESC>[5z	Graphics normal
√	*	*	*	*	<ESC>[6~	Initialize the printer
√	*	*	*	*	<ESC>[6 SP K	Set horizontal pitch to 6 cpi
√	*	*	*	*	<ESC>[6w	Set 15 cpi
√	*	*	*	*	<ESC>[6z	Graphics inverted
√	*	*	*	*	<ESC>[7w	Set 17.1 cpi
√	*	*	*	*	<ESC>[7y	Proportional font OFF
√	*	*	*	*	<ESC>[7z	Bit 8 = unchanged
√	*	*	*	*	<ESC>[8w	Reset double stroke
√	*	*	*	*	<ESC>[8y	Right justification ON
√	*	*	*	*	<ESC>[8z	Set bit 8 = 0
√	*	*	*	*	<ESC>[9 SP L	Set vertical spacing to 2 lpi
√	*	*	*	*	<ESC>[9w	Set double stroke
√	*	*	*	*	<ESC>[9y	Centering ON
√	*	*	*	*	<ESC>[9z	Set bit 8 = 1
	√				<ESC>[g<n1> <n2><0>	Set graphics print to 60 dpi
	√				<ESC>[g<n1> <n2><1>	Set graphics print to 120 dpi
	√				<ESC>[g<n1> <n2><11>	Set graphics print to 180 dpi
	√				<ESC>[g<n1> <n2><12>	Set graphics print to 360 dpi

MTPL	IBM XL24	IBM AGM	Epson LQ-2550	Epson LQ-2170	Code	Function
	√				<ESC>[g<n1> <n2><2>	Set graphics print to 120 dpi
	√				<ESC>[g<n1> <n2><3>	Set graphics print to 240 dpi
	√				<ESC>[g<n1> <n2><8>	Set graphics print to 60 dpi
	√				<ESC>[g<n1> <n2><9>	Set graphics print to 120 dpi
			√	√	<ESC>[j	Position paper back 1/180"
√	*	*	*	*	<ESC>[<n1> <n2>f	Set absolute horizontal and vertical position
√	*	*	*	*	<ESC>[<n>+w	Interface holding time n = 1 - 30 s
√	*	*	*	*	<ESC>[<n>+x	Head position horizontal in n/720", also paper load pos.
√	*	*	*	*	<ESC>[<n>SP q	Load menu
√	*	*	*	*	<ESC>[<n1>...<n5>+v	Paper handling options
√	*	*	*	*	<ESC>[<n1>...<n16>SP r	Print transparent characters
√	*	*	*	*	<ESC>[<n1> <n2>f	Set absolute horizontal and vertical position
√	*	*	*	*	<ESC>[<n1> <n2>SP 0	Change character size
√	*	*	*	*	<ESC>[<n1> <n2>SP D	Select font
√	*	*	*	*	<ESC>[<n1> <n2>SP G	Set character/line spacing
√	*	*	*	*	<ESC>[<n1> <n2>r	Set top and bottom margin
√	*	*	*	*	<ESC>[<n1> <n2>s	Set left and right margin
√	*	*	*	*	<ESC>[<n> a	Set relative horizontal position
√	*	*	*	*	<ESC>[<n> d	Set absolute vertical position
√	*	*	*	*	<ESC>[<n> e	Set relative vertical position
√	*	*	*	*	<ESC>[<n> j	Relative horizontal position back (to the left)
√	*	*	*	*	<ESC>[<n> k	Relative vertical position back (to the top)
√	*	*	*	*	<ESC>[<n> p	Set HMI
√	*	*	*	*	<ESC>[<n> q	Set horizontal step
√	*	*	*	*	<ESC>[<n> SP \	Set additional spaces
√	*	*	*	*	<ESC>[<n> SP C	Select character size
√	*	*	*	*	<ESC>[<n> SP f	Set reduced spacing
√	*	*	*	*	<ESC>[<n> SP g	Set character spacing
√	*	*	*	*	<ESC>[<n> SP h	Line spacing
√	*	*	*	*	<ESC>[<n> SP s	Transmits the "n" character as an ASCII character (hex 0055)
√	*	*	*	*	<ESC>[<n> SP U	Beginning of line (default value)
√	*	*	*	*	<ESC>[<n> SP V	End of line (default value)
√	*	*	*	*	<ESC>[<n> t	Set form length in lines
√	*	*	*	*	<ESC>[<n> u	Set horizontal tab

MTPL	IBM XL24	IBM AGM	Epson LQ-2550	Epson LQ-2170	Code	Function
√	*	*	*	*	<ESC>[<n>v	Set vertical tab
			√	√	<ESC>[<n1><n2>	Perform relative horizontal step
	√				<ESC>\<n1>;<n2>	Transparent mode for the characters following
	√				<ESC>^	Transparent mode for the character following
	√				<ESC>_<n>	Overline ON/OFF
	√	√	√	√	<ESC>0	Set line feed to 1/8 inch
	√				<ESC>1	Set line feed to 7/72 inch
	√	√	√	√	<ESC>2	Set line feed to 1/6 inch
	√				<ESC>2	Set line feed to n/72 inch
		√	√	√	<ESC>3<n>	Set line feed to n/180 inch
	√				<ESC>3>n>	Set line feed to n/216 inch
			√	√	<ESC>4	Italics ON
	√	√			<ESC>4	Set beginning of form
			√	√	<ESC>5	Italics OFF
	√	√			<ESC>5<n>	Autom. line feed ON/OFF
			√	√	<ESC>6	Print ASCII codes dec. 129 to dec. 159
	√	√			<ESC>6	PC character set 2 (expanded)
			√	√	<ESC>7	Suppress ASCII codes 129 to 159
	√	√			<ESC>7	PC character set 1 (standard)
			√		<ESC>a<n>	Select orientation
		√	√	√	<ESC>A<n>	Line spacing n/60 inch
	√				<ESC>A<n>	Prepare line spacing n/72 inch
			√		<ESC>b<m><0>	Clear all tabs
			√		<ESC>b<m><n><0>	Set vertical tabs in channels
	√	√	√	√	<ESC>B<0>	Clear all vertical tabs
			√	√	<ESC>B<n1>...<n16><0>	Set vertical tabs
	√	√			<ESC>B<n1>...<n64><0>	Set vertical tabs
√					<ESC>c	Reset to initialization status
				√	<ESC>c	Setting the horizontal motion index (HMI)
	√	√	√	√	<ESC>C<0><n>	Set form length in inches
	√	√	√	√	<ESC>C<n>	Set form length in lines
	√	√		√	<ESC>d<n1> <n2>	Perform relative horizontal step
	√	√	√	√	<ESC>D<0>	Clear all horizontal tabs
	√	√	√	√	<ESC>D<n1>...<n32><0>	Set horizontal tabs
	√	√			<ESC><DC2>	Condensed printing OFF
	√	√			<ESC><DC4>	Double-wide printing OFF (set with <SO> or <ESC><SO>)

MTPL	IBM XL24	IBM AGM	Epson LQ-2550	Epson LQ-2170	Code	Function
	√	√	√	√	<ESC><SO>	Double-wide printing ON
			√	√	<ESC><SP><n>	Set character spacing
			√	√	<ESC>t<n>	Select character set
	√	√	√	√	<ESC>T	Superscript or subscript OFF
	√	√	√	√	<ESC>U<n>	Unidirectional print ON/OFF
			√	√	<ESC>Un	Unidirectional print ON/OFF
	√	√	√	√	<ESC>W<n>	Continuous double width ON/OFF
			√	√	<ESC>w<n>	Double height print ON/OFF
			√	√	<ESC>x<n>	Set print quality (PQ)
			√	√	<ESC>x<0>	sets Draft or HS-Draft
			√	√	<ESC>x<1>	sets LQ or NLQ
				√	<ESC>X	Font selection according to pitch and points
	√	√			<ESC>X<n><m>	Set left and right margin
	√	√	√	√	<ESC>Y<n1> <n2>	Set graphics print to 120 dpi
	√	√	√	√	<ESC>Z<n1> <n2>	Set graphics print to 240 dpi
√	*	*	*	*	<ESC>+F	Assign character set G3
√	*	*	*	*	<ESC>	Character generator LS3R
√	*	*	*	*	<ESC>}	Character generator LS2R
√	*	*	*	*	<ESC>~	Character generator LS1R
√	√	√	√	√	<FF>	Form feed
√	√	√	√	√	<HT>	Horizontal tab jump
√					<HTS>	Set tab stop at actual horizontal position
√					<IND>	Line feed without CR
√	√	√	√	√	<LF>	Line feed
√					<NEL>	Line feed with CR
√					<PLD>	Half step line feed
√					<PLU>	Half step line feed back
√					<RI>	Line feed without CR back
	√	√	√	√	<SI>	Condensed printing of 17.1 cpi ON
√					<SI>	Switching the character generator (SS 3)
	√	√	√	√	<SO>	Double-wide printing ON
√					<SO>	Switching the character generator (SS 2)
√	√	√	√	√	<VT>	Vertical tab jump
√					<VTS>	Set tab stop at current vertical position

7.2.1 PJL commands

These PJL commands can be used with internal Ethernet interface as well as with external TallyCom III Pocket interface.

This functionality may be activated via the parameter **Jobcntl** in the Advanced Menu.

Sequence	Brief description
"ESC"%-12345X@PJL	Universal Exit Language (UEL)
@PJL ECHO	ECHO command
@PJL EOJ @PJL EOJ NAME=	EOJ (End of Job) commands
@PJL INFO STATUS	INFO (Information Request) command
@PJL INFO CONFIG	INFO of the printer configuration
@PJL INFO VARIABLES	INFO of variables which can be set by
@PJL INFO MEMORY	INFO about the memory of the printer
@PJL USTATUS DEVICE = ON @PJL USTATUS DEVICE = OFF @PJL USTATUS DEVICE = VERBOSE @PJL USTATUS JOB = ON @PJL USTATUS JOB = OFF @PJL USTATUS PAGE = ON @PJL USTATUS PAGE = OFF @PJL USTATUSOFF	USTATUS (unsolicited status) commands
@PJL JOB NAME = @PJL JOB FILE = @PJL JOB START = @PJL JOB END = @PJL JOB COPY =	JOB (Start of Job) commands
@PJL ENTER LANGUAGE	Exit PJL and start normal parser
@PJL INFO USTATUS	List each type of unsolicited status
@PJL USTATUS TIMED	Enables timed unsolicited status

7.2.2 Barcode

Even the standard version of your printer has the possibility of using up to 23 different MTPL barcode types.



Barcode mode can be accessed within every emulation. The user can decide whether barcode is activated permanently or activated depending on the situation by means of an escape sequence.

The printer prints small barcode in 240 dpi and wider barcodes in 120 dpi.

7.2.3 List of available MTPL barcodes

Type	Barcode	Type	Barcode
A*	2/5 Matrix (default)	N	UPC A (with HRI)
B*	2/5 Industrial	O	UPC A (without HRI)
C*	2/5 Interleaved	P	UPC E (with HRI)
D*	Code 11	Q	UPC E (without HRI)
E*	BCD Matrix	R*	Delta Distance (IBM)
F*	Code 39	S	Code 128
G*	Codabar	T	EAN 128
H	EAN 8 (with HRI)	1)	US-Postnet
I	EAN 8 (without HRI)	1)	KIX Barcode
K	EAN 13 (with HRI)	1)	Royal Mail Customer Barcode
L	EAN 13 (without HRI)	1)	USPS Intelligent Mail Barcode
M*	MSI/modified PLESSEY		

*These barcodes may be printed out horizontal and vertical, the unmarked only horizontal.

1) See description on following pages.

The barcode types K, L, N, O may be expanded by using Add-On Barcodes: Add-On 2 and Add-On 5.

The information to be printed is transmitted in a “bracket” (DC4) A control sequence (Header) defines the parameters of the used barcode once (e.g. type, ratio, etc.). If no header is defined, the information in the “bracket” will be printed in Code 2/5 Matrix.



Please note that within the Barcode environment the barcode commands have priority in case of conflicts with the emulation.

Additional information is provided in the Barcode Programmer's Application Manual in our website www.dascom.com.

Resident Barcodes:

- 1 - Code 2/5 Industrial
- 2 - Code 2/5 Interleaved
- 3 - Code 39
- 4 - Code EAN-8 with clear text line
- 5 - Code EAN-8 without clear text line
- 6 - Code EAN-13 with clear text line
- 7 - Code EAN-13 without clear text line
- 8 - Code UPC-A with clear text line
- 9 - Code UPC-A without clear text line
- 10 - Code UPC-E with clear text line
- 11 - Code UPC-E without clear text line
- 12 - Code 128 EAN (also called EAN-128)
- 13 - Code 128
- 14 - U.S Postnet (fix format, non-scalable)

7.2.4 US Postnet barcode

Postnet is a special US-American type of barcode. Is printed in character size. Numeric values from 0 to 9 are printable.

After activating this barcode type, numeric characters from 0 (hex. 30) to 9 (hex. 39) are interpreted as barcode figures. All other characters terminate the Barcode mode.

Exception: the TAB function (hex. 09) is allowed within Barcode mode. The Postnet sequence is accessible in every emulation.



The character (e.g. CR = carriage return, hex. 0D), which terminates the barcode is not printed or carried out. US Postnet barcode does not require a barcode bracket.

Example:

ASCII	ESC	[1	SP	P	1	2	3	4	5	CR
HEX	1B	5B	31	20	70	31	32	33	34	35	0D

The numbers 1 to 5 are printed as Postnet stripes.

7.2.5 Royal Mail Customer barcode

The Royal Mail Customer barcode is a special Mail type barcode. It is printed in character size. Numeric values from 0 to 9 and alpha-numeric values from A to Z are printable. After activating this barcode type, numeric characters from 0 (hex.30) to 9 (hex. 39) and alphanumeric values from A (hex. 41) to Z (hex. 5A) are interpreted as barcode figures. Lower cases from a (hex. 61) to z (hex. 7a) are automatically converted to capital characters. Control characters from hex. 0 (dec. 0) to hex.1F (dec. 31) terminates this barcode mode. All other characters are ignored. Exception: the TAB function (hex. 09) is allowed within Barcode mode. The Royal Mail Customer sequence is accessible in MTPL emulation. The printer prints barcode in LQ.



The character (e.g. CR = carriage return, hex. 0D), which terminates the barcode is not printed or carried out.

Royal mail customer barcode does not required barcode bracket.

Example:

ASCII	ESC	[1	SP	k	S	O	3	6	X	Y	1	A	CR
HEX	1B	5B	31	20	6B	53	4F	33	36	58	59	31	41	0D

The characters "SO36XY1A" are printed as Royal Mail Customer stripes.

7.2.6 KIX barcode

The KIX barcode prints numeric values from 0 to 9 and alpha-numeric values from A to Z as barcode characters.

After activating this barcode type, numeric characters from 0 (hex. 30) to 9 (hex. 39) and alphanumeric values from A(hex. 41) to Z (hex. 5A) are interpreted as barcode figures. Lower cases from a (hex. 61) to z (hex. 7a) are automatically converted to capital characters. Control characters from hex. 0 (dec. 0) to hex.1F (dec. 31) terminates this barcode mode. All other characters are ignored. Exception: the TAB function (hex. 09) is allowed within Barcode mode. The KIX sequence is accessible in MTPL emulation. The printer prints barcode in LQ.



The character (e.g. CR = carriage return, hex. 0D), which terminates the barcode is not printed or carried out. KIX barcode does not require a barcode bracket.

Example:

ASCII	ESC	[2	k	S	O	3	6	X	Y	1	A	CR
HEX	1B	5B	31	6B	53	4F	33	36	58	59	31	41	0D

The characters "SO36XY1A" are printed as KIX stripes.

7.2.7 USPS Intelligent Mail barcode

The USPS Intelligent Mail barcode is a 4-state barcode which works in MTPL, IBM and Epson emulation. 4-state barcode data must be converted into only 0, 1, 2 or 3. Each number represents one of the four possible bars. Tabs (Hex 09) and spaces can separate either the bars or the barcodes horizontal, but every other character below Hex 20 will terminate barcode mode.

You can enter the barcode mode with the sequence ESC [? 11 ~, the sequence ESC [10 ~ exits the barcode mode.

Example:

ASCII	ESC	[9	SP	K	<data>
HEX	1B	5B	39	02	6B	<data>

7.2.8 LC printing

Certain professional applications may require unusually Large character sizes. Therefore your printer has the possibility of scaling standard size characters up to factor 99 by means of control sequences (LCP*).

The Header sequence defines the parameters (e.g. height) once. This definition remains until the printer is switched off. The printable LCP* information is transmitted in an LCP “bracket” (SI).

The following character sets (with national characters) are available

.	ID	23	24	40	5B	5C	5D	5E	60	7B	7C	7D	7E
US ASCII	01	#	\$	@	[\]	?	`	{		}	~
GERMAN	02	#	\$	§	Ä	*	Ü	?	`	ä	*	ü	ß

The character sets are selected via the following LCP sequence ESC "P" "L" "S" n ESC "\". The value of n may range between 01 and 02 (as ASCII characters) – see ID column in the above table.

To select e.g. the German character set, you must use the following data set:

ASCII	ESC	P	L	S	0	1	ESC	\
HEX	1B	50	4C	53	30	31	1B	5C
DEC	27	80	76	83	48	49*	27	92



The printout of LCP characters can be selected in all of the emulations. Prerequisite: Printer must be in Barcode mode.

Note that this printer also supports some scalable fonts in the LQ-2170 emulation if a compatible driver is used.

7.2.9 List of additional control Codes

You can use both the ESC sequences and the control codes

Sequences	Control codes	Function
<ESC>[?10~	—	Barcode Off
<ESC>[?11~	—	Barcode On
<ESC> PSC 0 <ESC> \	—	Unsecured mode
<ESC> PSC 1 <ESC> \	—	Secured mode LCP
<ESC> PLS <n> <ESC> \	—	character set
<ESC>[<n><SP>s	—	Sends a character as ASCII character; n > 0–255 decimal
<ESC>[20<SP>s	<DC4>	Barcode bracket
<ESC>[16<SP>s	<DLE>	Start code LCP Header
<ESC>[25<SP>s		Termination code Header
<ESC>[15<SP>s	<SI>	LCP bracket
<ESC>[26<SP>s	<SUB>	Start code Barcode-Header
<ESC>[1 SP p	—	US-Postnet Barcode
<ESC>[1 SP k	—	Royal Mail Customer Barcode
<ESC>[2 SP k	—	Kix-Barcode
<ESC>[9 SP k	—	USPS Intelligent Mail Barcode

Header	Function
<DLE> [!] nn EM	LCP header [] = optional nn = factor
<SUB> [F] a [nn][;xyz][;p] EM	Barcode header [] = optional a = Barcode type p = 0: Barcode horizontal p = 9: Barcode vertical



Additional information is provided in the Barcode Programmer’s Application Manual in our website www.dascom.com.

7.3 Interfaces Specifications

Your matrix printer offers connectivity via a parallel interface, USB and Ethernet interface. Serial I/O RS232C interface is an option. This appendix informs you about the parallel Interface, USB, Ethernet interface and optional serial interface RS232C, and describes the communication between your computer and the printer.

These interfaces are linked to form a called shared interface. Your printer can be configured to use only one interface or three alternately. When only one interface is used, it is monitored by the printer. If the printer is configured to use three interfaces simultaneously it monitors all interfaces for incoming data. As soon as the printer recognizes a signal, it switches to the respective interface and sends the BUSY signal to the other interface. After finishing the data transmission, the printer remains switched to the interface for a certain period of time (30 seconds). When this time has elapsed, the controller again enables all interfaces and the sequence described restarts. If incoming data is on the other interface and the current print position is not "Top of Form", a form feed is carried out.

7.3.1 Parallel I/O IEEE 1284

The bidirectional parallel interface offers the “nibble” mode of IEEE1284 interface. This enables installation in accordance with Windows “Plug & Play”.

The standard parallel interface is able to transfer data at a speed of max. 30, 000 bytes per second. When the receiving buffer is full, the data input is blocked until the data buffer is empty.

Connector assignment

Connector no.	Direction Printer-PC	Signal
1	←	STROBE (active low)
2	←	DATA 1
3	←	DATA 2
4	←	DATA 3
5	←	DATA 4
6	←	DATA 5
7	←	DATA 6
8	←	DATA 7
9	←	DATA 8
10	→	ACK (active low)
11	↔	BUSY
12	↔	PAPER EMPTY (PE)
13	↔	SELECT
14		AUTO FEED (active low)
15	- - -	not used
16	-	SIGNAL GROUND
17	←	CHASSIS GROUND
18	↔	5 V (Imax = 500 mA)
19-30	-	SIGNAL GROUND INIT
31		(active low) ERROR
32	←	(active low) SIGNAL
33		GROUND not used
34-35		SELECT IN
36		

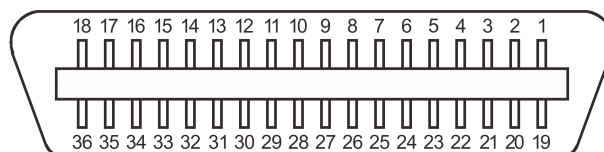

Transmission length: max. 2,0 m

7.3.2 Ethernet I/O 10/100 Multiprotocol

The Ethernet interface enables the printer to connect to local area networks. Its attributes are:

Hardware	LAN/Ethernet: RJ45, Ethernet 100BaseTX with 100 Mbps (IEEE802.3u), 10Base-TX with 10 Mbps (IEEE802.3) Speed: 100 Mbps / Full Duplex
Supported operating Systems	Windows XP, Windows Server 2003, Windows 2000, Windows NT, Windows 7, Windows 10, Windows Vista, Windows Server 2008, Windows Server 2013, Windows 8 Linux Unix Sun Solaris
Supported Protocols	SNMP SMTP TCP/IP FTP lpr / lpd Port 9100
Designation of IP Address	DHCP BOOTP Static (manually via the printer's control panel)
Configuration	HTTP TCP/IP
Status	SNMP TCP/IP SMTP PING
Management	Web Panel HP Web Jet Admin Pre-string, Post-String, String Replacement
Setup	Setup via the printer's control panel Web Panel (HTTP/HTML)

Ethernet TCP/IP

When using your printer in a local network with Ethernet connections and the TCP/IP protocol, you have to assign address information.



Address information for the Ethernet Port can only be made available by your network administrator, who has the necessary rights to install Printers on the network and/or make any changes.

Example of a Printer connected to a computer in an Network(IPv4)

- The assumed address space corresponds to the TCP/IP address, class C, 192.168.1.xxx.
- The subnet mask to be used is 255.255.255.0.
- The address of the router, or gateway, is 0.0.0.0, if not available.

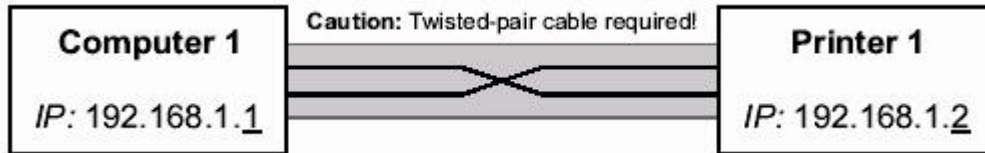

Example of several devices in an Ethernet

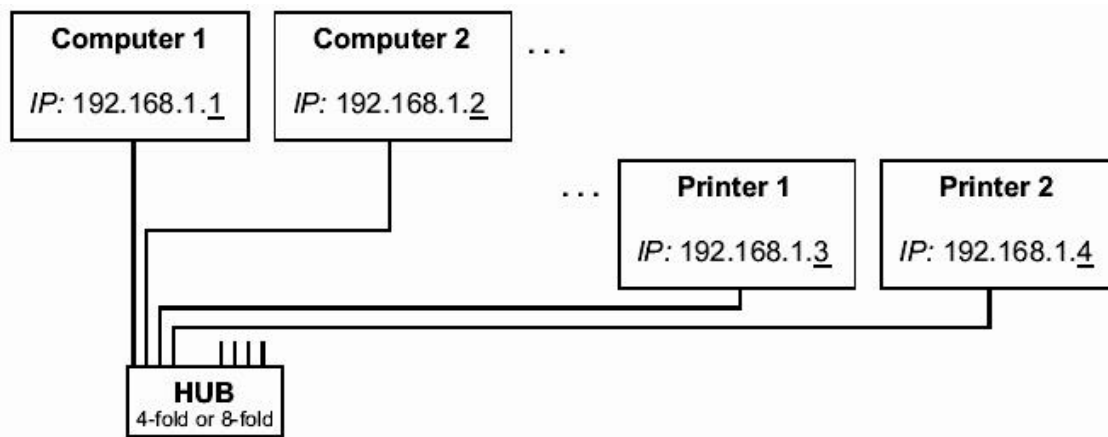

7.3.3 USB 2.0 I/O – Full Speed

The USB interface conforms to the Universal Serial Bus 2.0 Specifications. It supports the Full Speed mode at 12 Mbps. It uses the “B” type USB connector.

7.3.4 Optional Serial Interface RS232C

Your printer's serial interface supports the RS232C specification. The signals are received and transmitted by a 9 pin connector.

Basically 3 lines are enough for exchanging information between computer and printer (one receive line, one send line, one line for common grounding).

Type	RS232C interface
Synchronization	Asynchronous
Transmission rate	600 Baud to 19200 Baud
Signal status	OFF (log.1) -3 V to -15 V ON (log. 0) +3 V to +15 V
Connection cable	up to 15 m length
Interface connections	ITT Cannon connector, series DB-9 S
Transmission protocol	XON/XOFF, ENQ/STX, READY/ BUSY, Robust XON/XOFF, ETX/ ACK, ACK/NAK
Capacity of data buffer	512Byte min. 256KByte max

Connector assignment

Connector no.	Direction Printer-PC	Signal
3	→	TxD
4	→	DTR
2	←	RxD
6	←	DSR
7	→	RTS
8	←	CTS
5	—	Signal Ground SG
Shield	—	Frame Ground FG

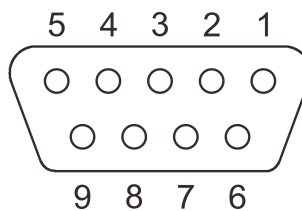



- 1) The serial cable length must not exceed 15 meters.
- 2) Make sure the "Interface Setup" selects serial interface and the settings are the same as PC communication port settings. See example below:

```
Serial
Baud          9600
Format 8Bit No 1Stop
Protocol      XON/XOFF
DTR           DTR
```

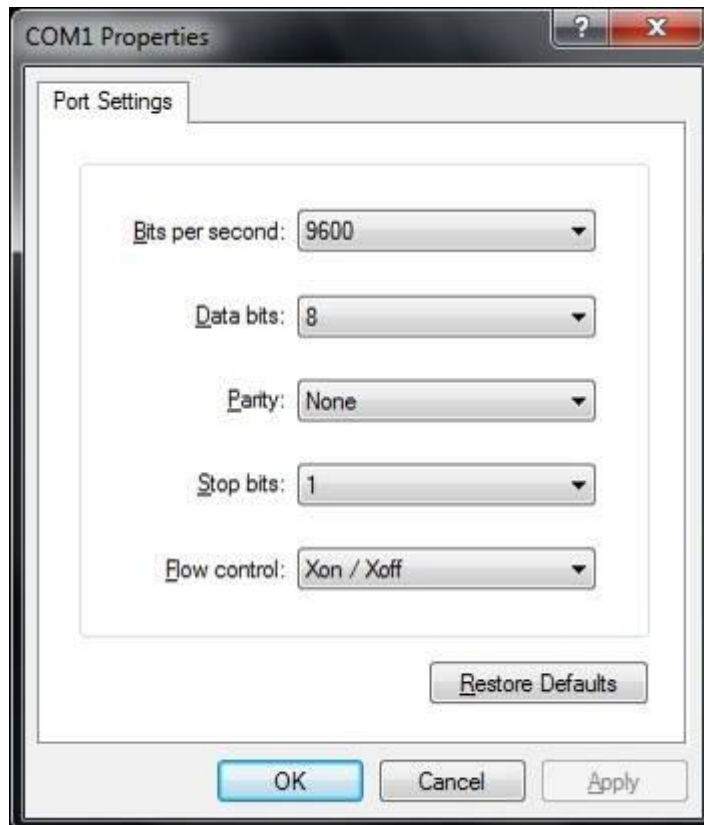

Interface cable (serial interface)

The cables used must be shielded. The cable shield must be connected to the connector shield on both ends.

PC/AT (9 Pin)		Printer (9 Pin)	
RxD	2	3	TxD
TxD	3	2	RxD
CTS	8	4	DTR/RDY
SG	5	5	SG
DSR	6		
DTR	4		

PC/AT (25 Pin)		Printer (9 Pin)	
FG	1	FG	
TxD	2	2	RxD
RxD	3	3	TxD
CTS	5	4	DTR/RDY
SG	7	5	SG
DSR	6		
DTR	20		



It depends on the menu setting whether DTR or RDY (Ready) is active at Pin 4.

● Input signals

Signal	Function
CTS	Clear to Send
DSR	Data Set Ready
RxD	Receive Data

● Output signals

Signal	Function
DTR	Data Terminal Ready
RTS	Request to Send
READY	Ready to receive data
TxD	Transmit Data

Protocols

- **Memory mode XON/XOFF**

The received characters are stored in a FIFO buffer (first in/first out).

The characters are processed in this buffer.

The buffer capacity can be adjusted from 0 to 256 Kb.

If the buffer is full, the interface signals NOT READY (signal acknowledgement: Level 1, -12 V) and XOFF (hex. 13, dec. 19). This results in stopping the data transmission. When the FIFO buffer is empty again, the interface signals READY (level 0, +12 V) and XON (hex.11, dec. 17). Data transmission can be continued.

In addition, the READY signal is influenced by the status of the printer (On/Off Line). If the printer assumes an undefined state, the interface also signals NOT READY and XOFF.

- **Memory mode Robust XON/XOFF**

Robust XON/XOFF is similar to XON/XOFF. However, the state of the printer (XON or XOFF) is also periodically transmitted via the TxD line in the case of Robust XON/XOFF.

- **Extended menu functions with the ENQ/STX and ETX/ACK protocols selected**

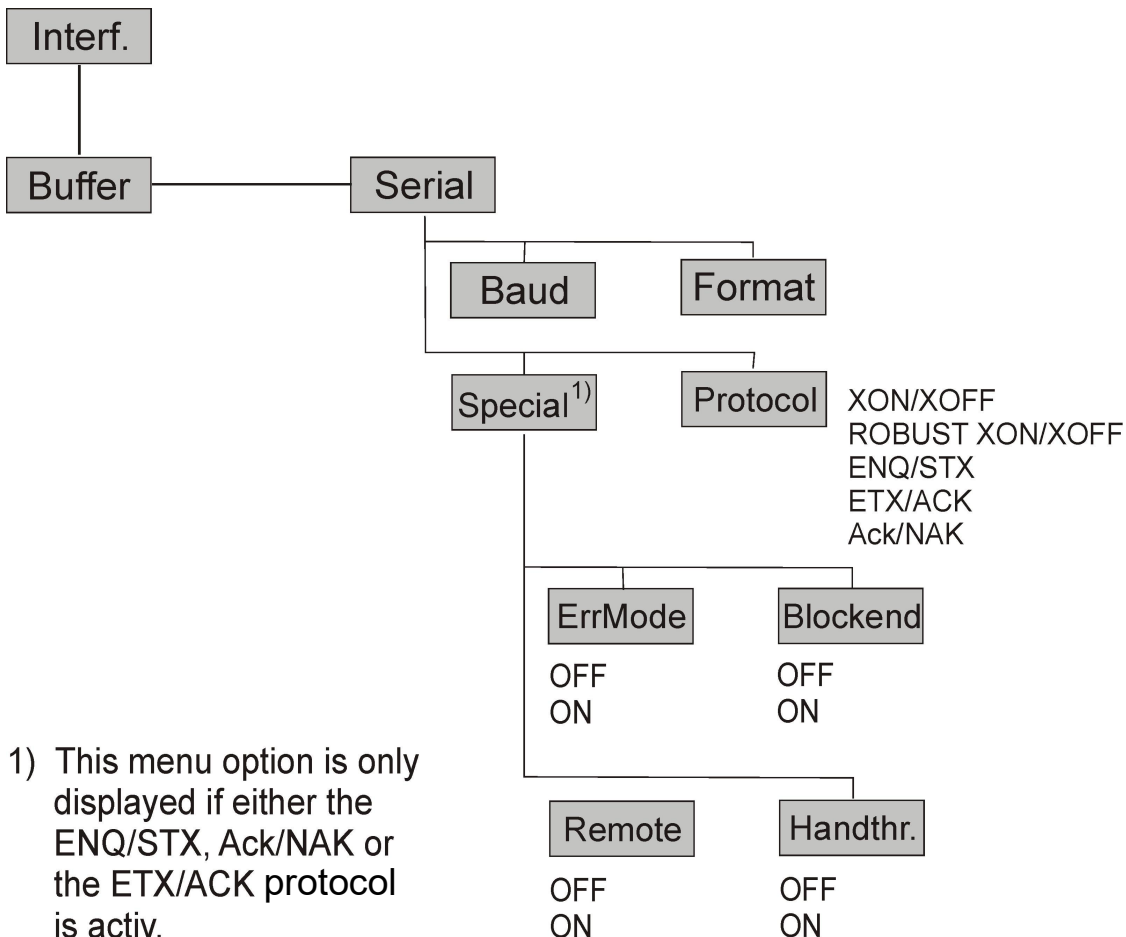

● ENQ/STX protocol

In addition to this XON/XOFF message, the possibility exists of requesting a status byte from the printer using the ENQ code (hex. 05, dec. 5). The STX code (hex 02, dec. 2) is used to clear any error messages (parity error, buffer overflow).

Status byte	Bit 0-1	BUSY
	Bit 1-1	Off Line
	Bit 2-0	Paper end
	Bit 3-1	Always 1
	Bit 4-1	Cover open
	Bit 5-1	Buffer overflow
	Bit 6-1	Parity or frame error
	Bit 7-0	Always 0

STX (hex02): Clears any previous parity or framing error as well as any buffer overflow error.

ENQ (hex05): The current printer status is sent to the host.

XON/XOF: This protocol is automatically used for data flow control and printer status handling.

HandThr.= ON: The STX and ENQ characters are not filtered out of the data stream and control the interface in addition.

HandThr.= OFF: The STX and ENQ are filtered out of the data stream and handled immediately by the interface.

● ETX/ACK protocol

ETX (hex03): Acknowledgement informing the host that further data may be transmitted.

XON/XOFF: This protocol is used in addition to data flow control and printer status handling.

ACK (hex06): Block end character.

HandThr.=ON: An ETX is not acknowledged by ACK before all previously arrived data have been printed

HandThr. =OFF: When the printer receives an ETX, it returns an ACK to the host. Any previously sent data or blocks may still be present in the printer buffer.

● ACK/NAK protocol

The ACK/NAK Protocol is a so called block Protocol.

Normally the Blocks are starting with the Block Start Character (STX, dec 02, hex 02) and end with a Block End Character (ETX, dec 03, hex 03).

As soon as a Block is received by the printer it acknowledges it with the Acknowledge Character (ACK, dec 06, hex 06).

If there is an Error in the transmission a Not-Acknowledge-Character (NAK, dec 21, hex 15) is being sent back. As a block end character other codes are possible.

One can check the printer condition/status; During the transmission of graphic data or download character per se problems can come up within the block mode as in this data block end characters can be transmitted as normal graphic or other data.

7.3.5 USB A Host

With this additional connectivity it is possible to improve the serviceability for example to load the firmware or to upload or download Configuration easily by an USB stick.

Further information, please see chapter [5.5](#).



8 Options and accessories

The following options can be ordered for your printer.

8.1 Options

Tractor Unit 2600+

Name	Part no.
Second Tractor for push and pull position (rear, top and front installable).	99992

Tractor Unit 2610+

Name	Part no.
Second Tractor for push and pull position (rear, top and front installable).	99993

Serial Interface 2600+/2610+

Name	Part no.
Serial Interface RS232C, 9pin female	99995

8.2 Consumables

Ribbons

Name	Part no.
Ribbon cassette monochrome black for narrow model (with ribbon guide)	99003L
Ribbon cassette monochrome black for wide Model (with ribbon guide)	99004L

Refill Kits

Name	Part no.
Refill Kit monochrome black fabric for narrow model, on demand	99002
Refill Kit monochrome black fabric for wide model, on demand	99072

8.3 Accessories

Programming manuals

The following programming manuals are available. You can download the manuals from our internet page.

Name	Part no.
Programmer's application manual MTPL (in English)	379 298
Programmer's application manual Barcode (in English)	379 300
Programmer's application manual Epson (in English)	379 302

9 General Specifications

9.1 Printer Specifications

Print System	Uni-/bi-directional logic seeking for text and graphics					
Print Technology	Serial dot matrix printer					
Print Head	Number of pins: 24 pins (2 x 12; staggered) Firing frequency: Normal mode: 2.05 kHz Pin diameter: 0.25 mm Distance between pins: horizontal 1/20 inch, vertical 1/90 inch Life: 500 million strokes/pin @ Draft mode					
Print Speed	Pitch	HS Draft	Draft	C-Draft	NLQ	LQ (in CPS)
	10 CPI	600	513	342	228	114
	12 CPI	683	513	410	273	137
	15* CPI	513	513	513	342	171
	15 CPI	683	513	513	171	171
	17.1 CPI	568	293	292	195	195
	20 CPI	683	342	342	228	228
	*Default: Epson sub/superscript and MTPL micro					
Character Pitch	5 / 6 / 7.5 / 8.6 / 10 / 12 / 15 / 17.1 / 20 CPI (characters per inch)					
Print attributes in all character pitches	Double width / italics / right justification / shadowed / auto centered / double height bold / proportionally spaced / underlined / overlined / superscript / subscript; Scalable with special LQ fonts					
Character Size	Height: 3.32 mm (exclusive descenders) Width: max. 2.43 mm					
Font Matrix	Pitch	HS Draft	Draft	C-Draft	NLQ	LQ
	10 CPI	24x6	24x8	24x12	24x18	24x36
	12 CPI	24x6	24x8	24x10	24x15	24x30
	15* CPI	16x8	16x8	16x8	16x12	16x24
	15 CPI	24x6	24x8	24x8	24x18+6	24x18+6
	17.1 CPI	24x6+1	24x12+2	24x12+2	24x18+3	24x18+3
	20 CPI	24x6	24x10+2	24x12+2	25x15+3	24x15+3
Paper Feed	Feed speed: 5 ips (tractor and friction) Feed first line : 43 ms View / Tear position: 5 ips Reverse motion: up to max form length of 14 inches					
Tab Speed	60 ips					
Graphic Densities	Horizontal: 60 / 72 / 80 / 90 / 120 / 180 / 240 / 360 DPI (dot per inch) Vertical: 90 / 180 / 360 DPI					

*) Only with ESC/P (sub-/superscript, 15 CPI) and MTPL Micro-script

	Narrow version	Wide version
Print width	10 CPI: 80 CPL	136 CPL (characters per line)
	12 CPI: 96 CPL	163 CPL
	15 CPI: 120 CPL	204 CPL
	17.1 CPI: 137 CPL	233 CPL
	20 CPI: 160 CPL	272 CPL
Fonts resident	HS-Draft, Draft and C-Draft in Data Print Quality NLQ same as LQ with reduced matrix, LQ Roaman, Roaman PS, SansSerif SansSerif PS, Courier, Courier IBM, Courier IBM PS, OCR A, OCR B, Prestige, Script, Orator, Gothic, Souvenir DLL Character Set in Epson and IBM format	
Barcodes resident	Code 2/5 industrial, 2/5 Interleaved, Code 39 EAN-8/ HRI, EAN-13/ HRI, UPC-A/HRI, UPC-E/HRI, 128 EAN, Code 128, US Postnet, KIX Barcode, Royal Mail, USPS	
Emulation	MTPL, Epson ESC/P2 (LQ2170), Epson ESC P (LQ 2550), IBM PP XL 24e, IBM ProXL24+AGM, Epson FX(9pin)	
Code Pages National Character Sets	(see the font and code page matrix below)	
Line Spacing	2 LPI / 3 LPI / 4 LPI / 6 LPI / 8 LPI / 12 LPI / 1/72" / 1/180" / 1/360 inches	
Paper Handling	Feeding method: Friction (Single) and Tractor (FF-front / FF-rear / FF-pull) Path selection: By selection lever located at the right device side Paper path: Cut sheets: Front in, front or top out Fanfold paper: Front or rear in, top out For details enter the Paper Specifications – 9.3 below	
Ribbon Type	Ribbon Cartridge, monochrome; Wide version: 470 x 93 x 39mm max, (WxDxH), fabric: 13mm height Narrow version: 330 x 93 x 39mm max, (WxDxH), fabric: 13mm height	
Ribbon Life	Wide version: 15 million characters (Draft 10 cpi, Rolling ASCII) Narrow version: 10 million characters (Draft 10 cpi, Rolling ASCII)	
Windows Drivers	Windows Server 2000 / 2003 / 2008 / 2012 Windows 7 and Windows 8,8.1,10 (for 32 and 64bit versions) ➔ covers Windows XP, Windows 2000 and Windows Vista.	
Web Panel	Administration and configuration via Ethernet (remote control)	
Config Tool	Administration and configuration via USB, Ser and Par Interface.	
USB Host	Firmware and configuration loading	
Interfaces	Ethernet 10/100MHz Parallel (Bi-directional IEEE-1284 nibble mode) USB 2.0 (Full Speed 12 MHz, B type connector) For details enter the Interface Specifications – 7.3 above	
Interface optional	Serial RS 232 (9pin Sub-D)	
Input Data Buffer	Up to 256KB	

Operation Panel	6 keys and LCD with 2 lines x 16 characters, Backlight
Analyzing	Menu setting print out Rolling ASC II 80 or 136 Hex-Dump
Noise Level	Sound pressure level = ≤ 55 dB(A)
Environmental Conditions	<p>Temperature Operating: +10 to +35°C. Storage: - 5 to +45°C Transport: - 40 to +70°C</p> <p>Humidity Operating: 16 to 73% RH (No condensation) Storage: 5 to 95% RH (No condensation) Transport: 5 to 95% RH (No condensation)</p>
Dimensions	Wide version: 600 mm (W) x 267 mm (D) x 200 mm (H) Narrow version: 485 mm (W) x 267 mm (D) x 200 mm (H)
Weight	Wide version: 10.6 kg Narrow version: 8.1 kg
Power Supply	Unit type: Autosensing wide range power supply Power cord: Detachable Voltage rating: AC 100 to 240V / 47Hz to 63Hz Nominal power: 150W ESD: Comply with IEC801-2; Contact discharge: 4kV Air discharge: 8kV
Power consumption	Print mode (RMS power): 60W Sleep mode(standby): <2.3W
Fuse	T6.3AH/250V
Workload	17.000 pages/month
MTBF	20.000 hours
MTTR	< 15 minutes
Throughput	422 p/h in Draft mode according IEC 10561:1999 (ECMA 132)
Maintenance	No preventive maintenance is required
Regulatory	CE, UL, FCC, CCC (other national certs on demand)
Environment Protection	Rohs, WEEE, REACH, GPCO, Pack, EcoDesign
User	Quick Start Guide(GIG) multi-lingual User Manual, English with multi-lingual safety notes (other languages on demand)
Service	Maintenance Manual (English only)

9.2 Non-Scalable Fonts, Code Pages and National Character Sets

	ID for ESC R/ESC (High Speed Draft	Draft	Draft Copy	Roman	Sans Serif	Courier (incl. Courier IBM)	OCR-B	OCR-A	Prestige	Script	Orator	Gothic	Souvenir
ISO USA	42	X	X	X	X	X	X	X	X	X	X	X	X	X
ISO UK	41	X	X	X	X	X	X	X	X	X	X	X	X	X
ISO France	52	X	X	X	X	X	X	X	X	X	X	X	X	X
ISO Germany	4B	X	X	X	X	X	X	X	X	X	X	X	X	X
ISO Italy	59	X	X	X	X	X	X	X	X	X	X	X	X	X
ISO Sweden	48	X	X	X	X	X	X	X	X	X	X	X	X	X
ISO Norway	60	X	X	X	X	X	X	X	X	X	X	X	X	X
ISO Spain	5A	X	X	X	X	X	X	X	X	X	X	X	X	X
ISO Portugal	4C	X	X	X	X	X	X	X	X	X	X	X	X	X
Epson USA	00	X	X	X	X	X	X	X	X	X	X	X	X	X
Epson France	01	X	X	X	X	X	X	X	X	X	X	X	X	X
Epson Germany	02	X	X	X	X	X	X	X	X	X	X	X	X	X
Epson UK	03	X	X	X	X	X	X	X	X	X	X	X	X	X
Epson Denmark I	04	X	X	X	X	X	X	X	X	X	X	X	X	X
Epson Sweden	05	X	X	X	X	X	X	X	X	X	X	X	X	X
Epson Italy	06	X	X	X	X	X	X	X	X	X	X	X	X	X
Epson Spain I	07	X	X	X	X	X	X	X	X	X	X	X	X	X
Epson Japan	08	X	X	X	X	X	X	X	X	X	X	X	X	X
Epson Norway	09	X	X	X	X	X	X	X	X	X	X	X	X	X
Epson Denmark II	0A	X	X	X	X	X	X	X	X	X	X	X	X	X
Epson Spain II	0B	X	X	X	X	X	X	X	X	X	X	X	X	X
Epson Latin America	0C	X	X	X	X	X	X	X	X	X	X	X	X	X
Epson Korea	0D	X	X	X	X	X	X	X	X	X	X	X	X	X
Epson Legal	40	X	X	X	X	X	X	X	X	X	X	X	X	X
CRO-ASCII	3C	X	X	X	-	X	X	-	-	-	-	-	-	-
Arabic Farsi	96	-	-	-	*1	*1	*1	*1	-	-	-	-	-	-
Arabic Urdu	97	-	-	-	*1	*1	*1	*1	-	-	-	-	-	-
Greek DEC	46	X	X	X	-	X	-	-	-	-	-	-	-	-
ELOT 928 (Greek)	6C	X	X	X	-	X	-	-	-	-	-	-	-	-
CP437 Latin US	80	X	X	X	X	X	X	X	X	X	X	X	X	X
CP737 Greek	93	X	X	X	-	X	-	-	-	-	-	-	-	-
CP775 Baltic	A6	X	X	X	-	X	X	-	-	-	-	-	-	-
CP850 Latin 1	82	X	X	X	X	X	X	X	X	X	X	X	X	X
CP851 Greek	88	X	X	X	-	X	-	-	-	-	-	-	-	-
CP852 Latin 2	87	X	X	X	-	X	X	-	-	-	-	-	-	-
Tarama (Turkish)	A8	X	X	X	-	X	X	-	-	-	-	-	-	-
CP857 Turkish	8D	X	X	X	-	X	X	-	-	-	-	-	-	-
CP858 (IBM with €)	9E	X	X	X	X	X	X	X	X	X	X	X	X	X
CP860 Portugal	84	X	X	X	X	X	X	X	X	X	X	X	X	X
CP861 Icelandic	94	X	X	X	X	X	X	X	X	-	-	-	-	-
CP863 French Canada	85	X	X	X	X	X	X	X	X	X	X	X	X	X

	ID for ESC R/ESC (High Speed Draft	Draft	Draft Copy	Roman	Sans Serif	Courier (incl. Courier IBM)	Courier	OCR-B	OCR-A	Prestige	Script	Orator	Gothic	Souvenir
CP864 Arabic	8C	-	-	-	*1	*1	*1	*1	-	-	-	-	-	-	-
CP864Arab. Extended	95	-	-	-	*1	*1	*1	*1	-	-	-	-	-	-	-
CP865 Nordic	86	X	X	X	X	X	X	X	X	X	X	X	X	X	X
CP866 Cyrillic	8E	X	X	X	-	X	X	-	-	-	-	-	-	-	-
CP866 Bulgaria	9D	X	X	X	-	X	X	-	-	-	-	-	-	-	-
CP866 Ukraine	8F	X	X	X	-	X	X	-	-	-	-	-	-	-	-
CP866 Kazakhstan	90	X	X	X	-	X	X	-	-	-	-	-	-	-	-
Siemens Turkish	9B	X	X	X	-	X	X	-	-	-	-	-	-	-	-
DEC Turkish	9C	X	X	X	-	X	X	-	-	-	-	-	-	-	-
CP1250 Win Latin 2	70	X	X	X	-	X	X	-	-	-	-	-	-	-	-
CP1251 Win Cyrillic	71	X	X	X	-	X	X	-	-	-	-	-	-	-	-
CP1252 Win Latin 1	72	X	X	X	X	X	X	X	X	-	-	-	-	-	-
CP1253 Win Greek	73	X	X	X	-	X	-	-	-	-	-	-	-	-	-
CP1254 Win Turkish	74	X	X	X	-	X	X	-	-	-	-	-	-	-	-
CP1256 Arabic	76	-	-	-	*1	*1	*1	*1	-	-	-	-	-	-	-
CP1257 Baltic	77	X	X	X	-	X	X	-	-	-	-	-	-	-	-
8859-1 Latin 1	25	X	X	X	X	X	X	X	X	X	X	X	X	X	X
8859-1 Latin 1 (SAP)	2B	X	X	X	X	X	X	X	X	X	X	-	-	-	-
8859-2 Latin 2	26	X	X	X	-	X	X	-	-	-	-	-	-	-	-
8859-5 Cyrillic	2A	X	X	X	-	X	X	-	-	-	-	-	-	-	-
8859-6 Arabic	24	-	-	-	*1	*1	*1	*1	-	-	-	-	-	-	-
8859-7 Greek	2D	X	X	X	-	X	-	-	-	-	-	-	-	-	-
8859-9 Turkish	2E	X	X	X	-	X	X	-	-	-	-	-	-	-	-
8859-15 Latin 9 (Euro)	2F	X	X	X	X	X	X	X	X	X	X	-	-	-	-
BRASCII	6D	X	X	X	X	X	X	X	X	-	-	-	-	-	-
Abicomp	6E	X	X	X	X	X	X	X	X	-	-	-	-	-	-
Roman 8	4D	X	X	X	X	X	X	X	X	-	-	-	-	-	-
Coax/Twinax(Hebrew)	4F	X	X	X	X	X	*2	-	-	*3	*4	-	-	-	-
New-437 (Hebrew)	81	X	X	X	X	X	*2	-	-	*3	*4	-	-	-	-
New-DIG 850 (Hebr.)	83	X	X	X	X	X	*2	-	-	*3	*4	-	-	-	-
Old-Code 860 (Hebr.)	98	X	X	X	X	X	*2	-	-	*3	*4	-	-	-	-
Fiarro 863 (Hebrew)	99	X	X	X	X	X	*2	-	-	*3	*4	-	-	-	-
Table 865 (Hebrew)	9A	X	X	X	X	X	*2	-	-	*3	*4	-	-	-	-
Mazovia (Poland)	92	X	X	X	-	X	X	-	-	-	-	-	-	-	-
Kamenicky (Czech)	91	X	X	X	-	X	X	-	-	-	-	-	-	-	-

*1: only in 10 and 12 cpi, *2 : same as Sans Serif, *3 : same as Roman, *4 : only in 10 cpi

5 : HSD only in 10 and 12 cpi and as elongated 5 and 6 cpi

9.3 Paper Specifications

9.3.1 Standard Tractor (Front, Rear and Pull position) – narrow and wide versions

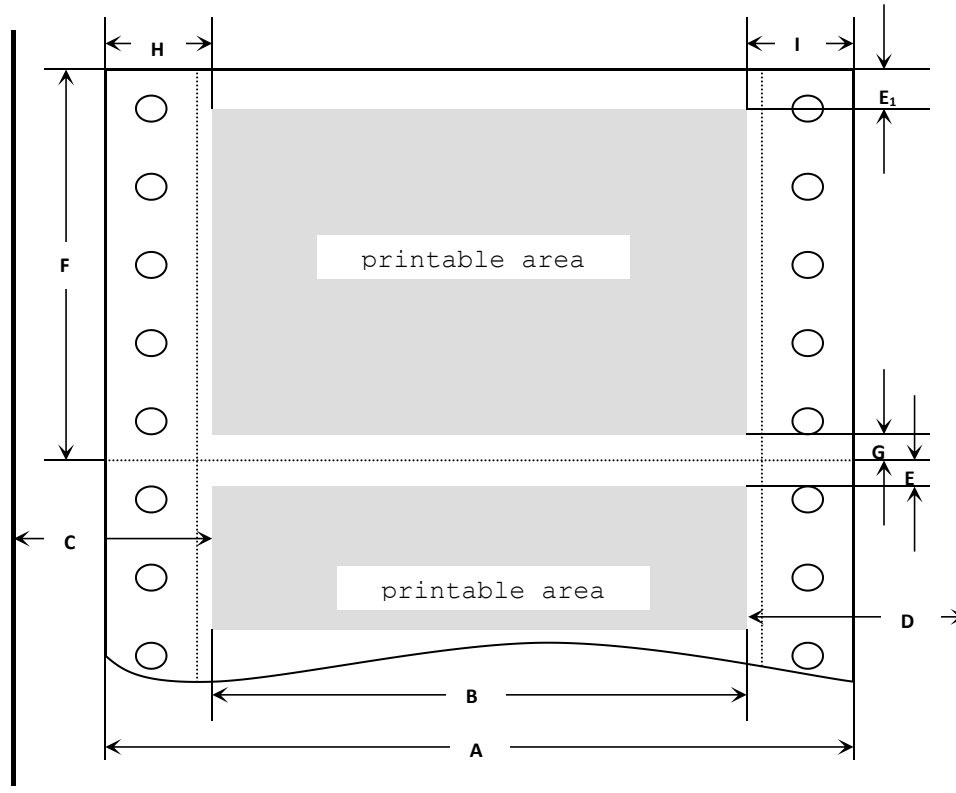

Usable figures of print area (dimensions in mm (inches))

Pos	Titel	Narrow model.		Wide.model	
		min	max	min	max
A	paper width,	76.2 (3")	278 (11")	76.2 (3")	420 (16.5")
B	printable line length		203.2 (8")		345.44 (13.6")
C	Max left tractor position to first printable character		38 (1.4")		38 (1.4")
D	Max right tractor position to first printable character		38 (1.4")		38 (1.4")
E	top margin ¹⁾	0 (0/72")	77.6 (220/72")	0 (0/72")	77.6 (220/72")
E ₁	top margin, default setting ¹⁾		4.23 (12/72")		4.23 (12/72")
F	form length ¹⁾	76,2 (3")	559 (22")	76.2 (3")	559 (22")
G	bottom margin	0	0	0	0
H	left margin, default setting "0" ¹⁾	0	198.1 (78/10")	0	340.4 (134/10")
I	right margin, default setting "80" ¹⁾ or "136/10"	2	203.2 (80/10")	2	345.44 (136/10")
	reverse paper feed for front and rear tractor path		356 (14")		356 (14")

¹⁾ Figure variable setting via interface or panel

9.3.2 Front Feed / Manual Insertion – Narrow and wide versions

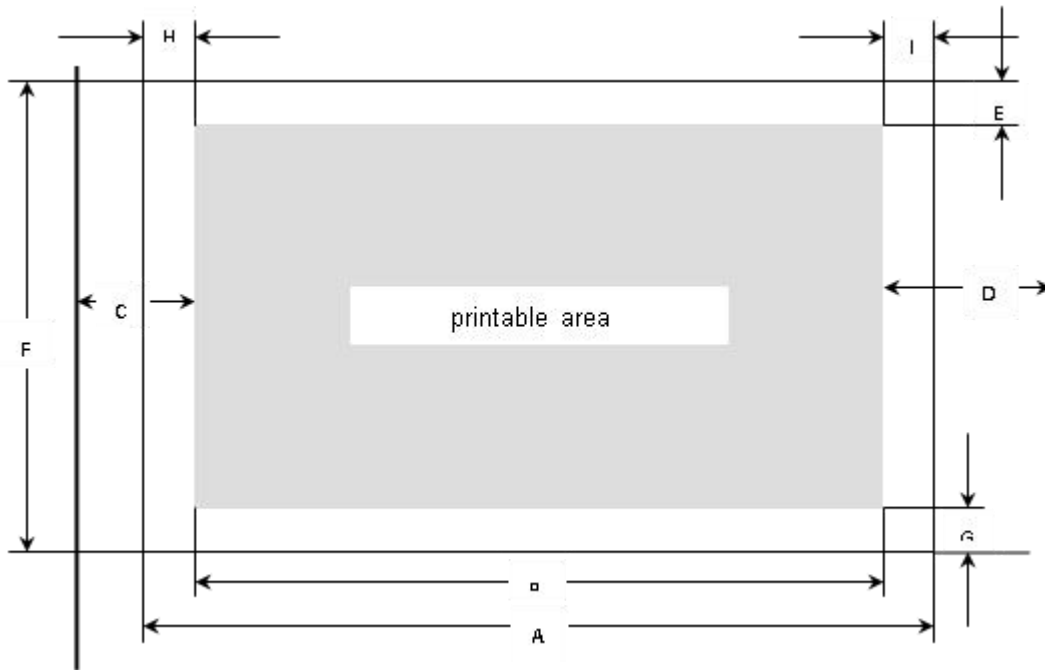

Usable figures of print area (dimensions in mm (inches))

Pos	Title	Narrow model		Wide model	
		min	max	min	max
A	paper width,	76 (3")	278 (11")	76 (3")	420 (16.5")
B	printable line length		203.2 (8")		345.44 (13.6")
C	Max left paper guide position to first printable character		38 (1.4")		38 (1.4")
D	Max right paper guide position to first printable character		38 (1.4")		38 (1.4")
E	top margin ¹⁾	0 (0/72")	77.6 (220/72")	0 (0/72")	77.6 (220/72")
E	top margin, default setting ¹⁾		4.23 (12/72")		4.23 (12/72")
F	form length	148 (5.8")	420 (16.5")	148 (5.8")	420 (16.5")
G	bottom margin	0	0	0	0
H	left margin, default setting "0" ¹⁾	0	198.1 (78/10")	0	340.4 (134/10")
I	right margin, default setting "80" or "136/10" ¹⁾	2	203.2 (80/10")	2	345.44 (136/10")
	reverse paper feed (front ejection)		420 (16.5")		420 (16.5")

9.3.3 Paper Weights

	Narrow and wide
Single Part Forms	60 – 120g/m ²
Number of copies	1 + 5
Multi Part Forms – original sheet	45 – 65g/m ²
Multi Part Forms – copy sheets	45 – 56g/m ²
Maximum thickness	0.50mm

¹⁾ Figure variable setting via interface or panel

10 Maintenance

Your printer requires very little care. Occasional cleaning and replacement of the ribbon cartridge are all that is required. Cleaning is recommended approximately every 6 months or 300 hours of operation, whichever is sooner. Lubrication of the printer is not usually necessary. If the print head carriage does not move smoothly back and forth, clean the printer in the manner described in this chapter. If the problem continues, contact your dealer.



Switch printer off and unplug the power cord from the mains before doing any maintenance work.

10.1 Cleaning

The housing and the top cover of the printer help protect it against dust, dirt, and other contaminants. However, paper produces small particles that accumulate inside the printer. This section explains how to clean and vacuum the printer and how to clean the paper bail rollers. It is easier to clean the printer when the cover is open.

10.1.1 Cleaning and Vacuuming the Printer

If the print head carriage does not move smoothly back and forth or paper particles have accumulated in the printer, clean the printer.

To clean and vacuum the printer:

- 1) Remove any paper from the printer. Make sure that the power is off, and then disconnect the printer power cord.
- 2) Using a soft vacuum brush, vacuum the exterior of the printer. Also vacuum the cut sheet edge.
- 3) Use a soft, damp cloth to wipe the exterior of the printer, including the cover. A mild detergent may be used. Do not use solvents, kerosene, or abrasive cleaning materials that may damage the printer.
- 4) Open the cover of the printer and remove the ribbon cartridge. Using a soft vacuum brush, gently vacuum the platen, the print head carriage and shaft, and surrounding areas. You can easily slide the print head to the left or right when the power is off. Be careful not to press too hard on the flat head cable that extends from the print head carriage.
- 5) Re-install the ribbon cartridge.

10.1.2 Cleaning the Paper Rollers

Clean the platen and paper bail rollers occasionally or when stains or smudges appear on the paper. Use a mild detergent as appropriate. Do not use alcohol to clean the platen or the rollers. Alcohol may cause the rubber to harden.

To clean the rollers and the platen:

- 1) Apply a small amount of water to a soft cloth. Avoid spilling liquid inside the printer.
- 2) Place the cloth against the platen and manually rotate the hand wheel.
- 3) Repeat this procedure for each roller.
- 4) To dry the platen, place a dry cloth against the platen and the rollers and manually rotate the paper feed knob.

10.2 Troubleshooting

Your printer is extremely reliable, but occasionally problems may occur. This chapter provides information on some of the common problems you may encounter and how you may solve them. If you encounter problems that you cannot resolve, contact your dealer or service partner for assistance.

10.2.1 Print Quality Problems and Solutions

Problem	Solution
Printing is too light or too dark.	<ul style="list-style-type: none"> • Make sure that the ribbon cartridge is properly installed and that the ribbon feeds smoothly. • Replace the ribbon if necessary. • Make sure that the print gap lever is set for the thickness of your paper.
Smears and stains appear on the page.	<ul style="list-style-type: none"> • Make sure that the print gap lever is set for the thickness of your paper. • Check for ribbon wear. Replace the ribbon if necessary. • Check whether the tip of the print head is dirty. Clean the head with a soft cloth if necessary. • The print head may need to be replaced.
Printing is erratic or the wrong characters are printed. Many “?” or unexpected characters are printed.	<ul style="list-style-type: none"> • Make sure that the interface cable is securely connected to both the printer and computer. • Make sure that the printer driver selected in your software is the same as the emulation selected on the printer. • Check the length of the interface cable. (Maximum Parallel & USB: 2 meters, Serial: 15 meters) • Try another interface cable.
The page is blank.	<ul style="list-style-type: none"> • Make sure that the ribbon cartridge is properly installed. • Make sure the gap lever is set correctly.
The top margin is wrong.	<ul style="list-style-type: none"> • Check the application top margin setting. • Adjust the Top Margin setting in Page Setup menu if necessary.
Lines are double spaced instead of single spaced.	<ul style="list-style-type: none"> • Change the Auto LF setting in the System Setup menu to No.
The printer overprints on the same line.	<ul style="list-style-type: none"> • Change the Auto CR setting in the System Setup menu to No.
The next print line starts where the previous line ended instead of at the left margin.	<ul style="list-style-type: none"> • Change the Auto CR setting in the System Setup menu to Yes.

10.2.2 Paper Handling Problems and Solutions

Problem	Solution
Paper cannot be loaded or fed.	<ul style="list-style-type: none"> • Make sure that the paper select lever located on the top right of the printer is set correctly.
Paper jams while loading.	<ul style="list-style-type: none"> • Turn off the printer and remove the jammed paper. Remove any obstructions from the paper path. • Make sure that the Print Gap lever is set for the thickness of your paper. • Make sure that the paper is not folded, creased, or torn. • Make sure that the left and right tractors are set so that the continuous forms are stretched tightly.
Paper jams while printing.	<ul style="list-style-type: none"> • Turn off the printer and remove the jammed paper. Remove any obstructions from the paper path. • Make sure that the Print Gap lever is set for the thickness of your paper. • For continuous forms, make sure that the incoming and outgoing paper stacks are correctly placed. Paper should feed straight.
Paper slips off the forms tractors or the perforated holes of the paper tear during printing.	<ul style="list-style-type: none"> • Make sure that the forms tractors are positioned correctly for the width of your paper and that the perforated holes of the paper fit directly over the tractor pins.

10.2.3 Operating Problems and Solutions

Problem	Solution
The power does not turn on.	<ul style="list-style-type: none"> • Check whether the mains voltage is correct. • Make sure that the power cord is securely connected to both the printer and the mains power outlet. • Make sure that the power outlet is functional. If not, use other outlet. • Turn the power off. Wait a minute and then turn the printer on again. If the printer still has no power, contact your dealer.
The printer is on but it will not print.	<ul style="list-style-type: none"> • Make sure that the Online indicator is lit. • If you use the interface cable, make sure it is securely connected to both the printer and the computer. • Make sure paper is loaded. • Run the printer Status Page. If printing executes normally, the problem is caused by: the interface, the computer, incorrect printer settings, or incorrect software settings. • Make sure that the printer driver selected in your software is the same as the emulation selected on the printer.
Paper select lever error	If paper is loaded and the paper select lever is moved to the incorrect position, the printer turns offline, and the buzzer sounds continuously. Switch the paper select lever back to its correct position.

FCC STATEMENT

Changes or modifications not expressly approved by the responsible for compliance could void the user's authority to operate the equipment.

NOTE: This equipment has been tested and found to comply with the limits for a class B digital device, pursuant to Part 15 of the FCC Rules. These limits are designed to provide reasonable against harmful interference in a residential installation. This equipment generates, uses and can radiate radio frequency energy and, if not installed and used in accordance with the instructions, may cause harmful interference to radio communications. However, there is no guarantee that interference will not occur in a particular installation. If this equipment does cause harmful interference to radio or television reception, which can be determined by turning the equipment off and on, the user is encouraged to try to correct the interference by one or more of the following measures:

- Reorient or relocate the receiving antenna.
- Increase the separation between the equipment and receiver.
- Connect the equipment into an outlet on a circuit different from that to which the receiver is connected.
- Consult the dealer or an experienced radio/TV technician for help.

DASCOM REPRESENTATIVES

GERMANY

DASCOM Europe GmbH
Heuweg 3
89079 Ulm
Germany
Tel.: +49 (0) 731 2075 0
Fax: +49 (0) 731 2075 100
www.dascom.com

SINGAPORE (ASIA PACIFIC)

DASCOMAP Pte Ltd
2 Jurong East Street 21
05-42, IMM Building
Singapore 609601
Phone: +65 6760 8833
Fax: +65 6760 1066
www.dascom.com

FRANCE

DASCOM Europe GmbH
7, Impasse de la Chanée
77410 Annet Sur Marne
France
Phone: +33 (1) 85 42 24 00
www.dascom.com

UNITED KINGDOM

DASCOM GB Ltd
Hart House, Priestley Road,
Basingstoke, Hampshire
RG24 9PU, England
Phone: +44 (0) 1256 355130
Fax: +44 (0) 1256 481400
www.dascom.com

AMERICAS

DASCOM Americas Corporation
34 Lakeview Court
Verona, VA 24482
USA
Phone: +1 (877) 434 1377
Fax: +1 (877) 334 0549
www.dascom.com

CHINA

JIANGMEN DASCOM COMPUTER
PERIPHERALS CO., LTD
No.399, Jinxing Road,
Jianghai District Jiangmen,
P.R. China
www.dascom.com

“All rights reserved. Translations, reprinting or copying by any means of this manual complete or in part or in any different form requires our explicit approval. We reserve the right to make changes to this manual without notice. All care has been taken to ensure accuracy of information contained in this manual. However, we cannot accept responsibility for any errors or damages resulting from errors or inaccuracies of information herein.”